

MASTERING AIR TRANSFER

LOUVRES



CONTENTS

Overview	4
Applications	8
Support every step of the way	12
Renson's strengths	14
Online louvre selector	16
Selection criteria	18
Inside/outside	20
Installation method	22
Airflow	24
Rain resistance	28
Noise reduction	30
IP rating	31
Product overview	
Built-in louvres for outside applications	34
Glazed-in for outside applications	92
Surface-mounted louvres for outside applications	114
Roof turrets	140
Wall/ceiling louvres for inside applications	144
Door louvres for inside applications	168
Flood/convector grilles for inside applications	182
Options	190

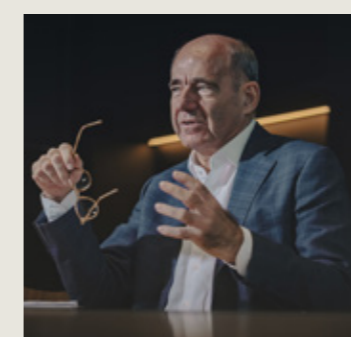

// *When developing innovative solutions, our main focus is on achieving harmony between technical performance and aesthetics. That way, we create architectural added value for every building.*
Paul Renson

//

PRODUCT OVERVIEW

Group	Louvre type	Page	Blade pitch (mm)	Materials	Airflow	Water resistance	Sound damping	Burglar resistance	Sand resistance	IP rating	Fire resistance
Outside/Built-in	411	36	33.3	Aluminium			n/a	n/a	n/a		n/a
	411R	40	33.3	Aluminium			n/a	n/a	n/a		n/a
	412	42	20	Aluminium			n/a	n/a	n/a		n/a
	412R	44	20	Aluminium			n/a	n/a	n/a		n/a
	421	46	50	Aluminium			n/a	n/a	n/a		n/a
	421R	48	50	Aluminium			n/a	n/a	n/a		n/a
	421RC2	50	50	Aluminium			n/a		n/a		n/a
	421RC3	52	50	Aluminium			n/a		n/a		n/a
	427	54	100	Aluminium			n/a	n/a	n/a	u/a	n/a
	434RD	56	n/a	Aluminium			n/a	n/a	n/a	u/a	n/a
	434RE	56	n/a	Aluminium			n/a	n/a	n/a	u/a	n/a
	435R	56	n/a	Aluminium			n/a	n/a	n/a	u/a	n/a
	445/86	58	60	Aluminium-mineral wool				n/a	n/a	u/a	n/a
	448D	60	150	Aluminium			n/a	n/a	n/a		n/a
	448/150	62	150	Aluminium-mineral wool				n/a	n/a	u/a	n/a
	448/225	64	150	Aluminium-mineral wool				n/a	n/a	u/a	n/a
	448/300	66	150	Aluminium-mineral wool				n/a	n/a	u/a	n/a
	449D	68	170	Aluminium			n/a	n/a	n/a		n/a
	449/150	70	170	Aluminium-mineral wool				n/a	n/a	u/a	n/a
	449/225	72	170	Aluminium-mineral wool				n/a	n/a	u/a	n/a
	450	74	50	Aluminium			n/a	n/a	n/a		n/a
	450V	76	50	Aluminium			n/a	n/a	n/a		n/a
	452	78	66	Aluminium			n/a	n/a	n/a		n/a
	457	80	75	Aluminium			n/a	n/a	n/a		n/a
	458	82	60	Aluminium			n/a	n/a	n/a		n/a
	468SA	84	n/a	Aluminium			n/a	n/a			n/a
480	86	60	Aluminium			n/a	n/a	n/a		n/a	
481	88	50	Aluminium			n/a	n/a	n/a		n/a	
491	90	33.3	Aluminium			n/a	n/a	n/a		n/a	
Outside/Glazed-in	414	94	33.3	Aluminium			n/a	n/a	n/a		n/a
	414R	96	33.3	Aluminium			n/a	n/a	n/a		n/a
	415	98	20	Aluminium			n/a	n/a	n/a		n/a
	415R	100	20	Aluminium			n/a	n/a	n/a		n/a
	424	102	50	Aluminium			n/a	n/a	n/a		n/a
	424RC2	104	50	Aluminium			n/a		n/a		n/a
	427GL	106	100	Aluminium	-	-	n/a	n/a	n/a	u/a	n/a
	483	108	60	Aluminium			n/a	n/a	n/a		n/a
	484	110	50	Aluminium			n/a	n/a	n/a		n/a
	494	112	33.3	Aluminium			n/a	n/a	n/a		n/a

u/a: Unavailable

n/a: Not applicable

Group	Louvre type	Page	Blade pitch (mm)	Materials	Airflow	Water resistance	Sound damping	Burglar resistance	Sand resistance	IP rating	Fire resistance
Outside/Surface-mounted	431	116	33.3	Aluminium			n/a	n/a	n/a		n/a
	431R	118	33.3	Aluminium			n/a	n/a	n/a		n/a
	431RC2	120	33.3	Aluminium			n/a		n/a		n/a
	432	122	33.3	Aluminium			n/a	n/a	n/a		n/a
	433L	124	99	Aluminium			n/a	n/a	n/a	u/a	n/a
	433S	126	36	Aluminium			n/a	n/a	n/a	u/a	n/a
	436	128	n/a	Aluminium			n/a	n/a	n/a	u/a	n/a
	437	130	n/a	Aluminium			n/a	n/a	n/a	u/a	n/a
	438	132	n/a	Aluminium			n/a	n/a	n/a	u/a	n/a
	439	132	n/a	Aluminium			n/a	n/a	n/a	u/a	n/a
	443	134	n/a	Aluminium			n/a	n/a	n/a	u/a	n/a
	633	134	37	Stainless steel			n/a	n/a	n/a	u/a	n/a
	638	136	n/a	Stainless steel			n/a	n/a	n/a	u/a	n/a
	641	136	n/a	Stainless steel			n/a	n/a	n/a	u/a	n/a
	733	138	40	PVC			n/a	n/a	n/a	u/a	n/a
	741	138	n/a	PVC			n/a	n/a	n/a	u/a	n/a
742	138	n/a	PVC			n/a	n/a	n/a	u/a	n/a	
Inside/Wall/Ceiling	381	146	n/a	Aluminium		n/a	n/a	n/a	n/a	n/a	n/a
	441	148	n/a	Aluminium		n/a	n/a	n/a	n/a	n/a	n/a
	464/1-Incendio	150	n/a	Polystyrene/Palusol		n/a	n/a	n/a	n/a	n/a	
	467	152	n/a	Polystyrene/Palusol		n/a	n/a	n/a	n/a	n/a	
	468AK1	154	n/a	Aluminium		n/a		n/a	n/a	n/a	n/a
	636	156	n/a	Stainless steel		n/a	n/a	n/a	n/a	n/a	n/a
	732	158	n/a	PVC		n/a	n/a	n/a	n/a	n/a	n/a
	735	158	n/a	PVC		n/a	n/a	n/a	n/a	n/a	n/a
	736	156	n/a	PVC		n/a	n/a	n/a	n/a	n/a	n/a
	4032	160	n/a	Aluminium		n/a	n/a	n/a	n/a	n/a	n/a
	4037	160	n/a	Aluminium		n/a	n/a	n/a	n/a	n/a	n/a
	Aeroo	162	n/a	Aluminium		n/a	n/a	n/a	n/a	n/a	n/a
	Design interior louvre	164	n/a	Aluminium		n/a	n/a	n/a	n/a	n/a	n/a
XD	166	n/a	Aluminium		n/a	n/a	n/a	n/a	n/a	n/a	
Inside/Door	461	170	n/a	Aluminium		n/a	n/a	n/a	n/a	n/a	n/a
	461AK-Silendo	172	n/a	Aluminium		n/a		n/a	n/a	n/a	n/a
	464/2-Incendio	174	n/a	Polystyrene/Palusol		n/a	n/a	n/a	n/a	n/a	
	468AK2	176	n/a	Aluminium		n/a		n/a	n/a	n/a	n/a
	469 - Invisido	178	n/a	Aluminium		n/a		n/a	n/a	n/a	n/a
	761	180	n/a	PVC		n/a	n/a	n/a	n/a	n/a	n/a
Floor and convector grilles	311	184	16.5	Aluminium		n/a	n/a	n/a	n/a	n/a	n/a
	392	186	13	Aluminium		n/a	n/a	n/a	n/a	n/a	n/a
	394	188	16.5	Aluminium		n/a	n/a	n/a	n/a	n/a	n/a

APPLICATIONS

Air is simply invaluable. We humans cannot live without it, and plants, animals and even machines also wouldn't survive without an adequate supply of fresh air.

It's no surprise then that openings to supply or extract air are all around us, inside and outside, in buildings and appliances, in homes and factories.

Depending on the application, these openings must be fit for purpose in many different ways—from keeping out rain and noise to deterring intruders and complementing the overall design. Renson offers custom solutions for each of these different situations.

We'll run you through just a handful of possible applications for our louvres below.



Night cooling

Night cooling, or ventilative cooling, is the principle of cooling a building during hot periods by circulating large amounts of fresh outdoor air through the building at night. This keeps the building pleasantly cool for longer during the day and can greatly reduce the amount of energy consumed by electric cooling systems.

- Standard: Type 431
- Removable: Type 432
- Burglar resistant and fall proof: Type 431RC2



Purge ventilation

When an enclosed space temporarily hosts activities it wouldn't normally see, it is sometimes necessary to extract or refresh large quantities of air. Examples include air pollution from the use of strongly scented products, moisture, or the presence of exceptionally large numbers of people.

Aside from that, many people also like the air they sleep in to be the same quality as outdoors. They might want to keep the window open, but without rain coming in, being bothered by insects, burglars trying their luck or traffic noise.

- Standard: Type 431
- Removable: Type 432
- Burglar resistant and fall proof: Type 431RC2
- Noise reducing: Type 445/86, and 448 and 449 series



Façade inlets or outlets for ventilation systems

Just about all residential buildings (homes, offices, hospitals or schools) are equipped with a ventilation system. The supply or extraction ducts of these systems often terminate through the façade, fitted with a suitable louvre. In larger buildings, these ducts are often installed above a suspended ceiling. As such, you'll often see strips of louvres at those levels, to which the ventilation ducts are connected.

- Standard glazed-in louvre: Type 414
- Glazed-in louvre with thermal break: Type 414THF
- High airflow glazed-in louvre: Type 483, 484



Noise-reducing solutions for loud technical systems

In densely populated areas, noise pollution is a major source of nuisance and can even lead to medical complaints. As such, it is important to make sure that loud systems such as heat pumps or spaces that produce a lot of noise are adequately soundproofed, especially when they are close to residential areas. A proper solution for the passage of air through the building shell is often essential for this.

- Renson offers a range of acoustic louvres, depending on the level of noise reduction needed: 445/86 – 448/150 – 448/225 – 448/300 – 449/150 – 449/225



Ventilation of electricity cabinets/spaces

Neighbourhoods are often supplied with electricity via the transformers that are such a familiar sight all through our streetscape. For large buildings, such installations are often fitted into the buildings themselves. Since heat extraction is essential for the proper functioning of these systems, this always involves some air openings with louvres, which are subject to special requirements in terms of safety and flow rate.

- Stick-proof and highly water-repellent (IP44): Type 412
- Lower stick-proof rating and water-repellent (IP23D): types 411, 421RC2, 421RC3



Room-to-room ventilation between different indoor spaces

Ventilation systems in buildings usually consist of supply and extraction vents at points in the building shell that are as far apart as possible. Usually, those points are in different rooms. As such, to achieve proper ventilation, air flow from the point of supply to the point of extraction must always be possible, even when internal doors are closed. And that makes door louvres an essential element in a well-functioning ventilation system.

- Our door louvres are available in different versions:
- Standard: Type 461 (aluminium), Type 761 (PVC)
 - Noise reducing: Silendo
 - Noise reducing + large flow rate: Type 468AK/2
 - Fire resistant: Type 464/2
 - Barely visible: Invisido



Basement ventilation

Basements often have no windows or doors opening to the outside through which sufficient fresh air can be supplied. To ensure healthy air quality here too or to avoid mould due to excessive damp, air can be supplied through air ducts and louvres.

- Round built-in louvre: Types 434RE, 435R
- Aluminium surface-mounted louvre: Types 431, 436, 437
- Stainless steel surface-mounted louvre: Types 438, 439



Extractor hood or tumble dryer vent

Domestic appliances such as extractor hoods or tumble dryers discharge moist air to the outside under pressure. In industrial settings too, certain applications discharge polluted or hot air to the outside on an intermittent basis. Typically, such applications use pressure relief vents that allow maximum airflow when operating and that shut when not operating.

- Residential (aluminium): 433S
- Residential (PVC): 733
- Industrial (aluminium): 433L



Fire-safe ventilation of (technical) spaces

Larger buildings or buildings with multiple residential units are often divided into multiple fire compartments. In this case, all walls, including any doors, must meet minimum fire resistance requirements to avoid rapid spread of fire. Typical examples include boiler rooms in apartment buildings or student halls.

- Built-in into a wall or ceiling, fire-resistant for 60 min.: Type 464/1
- Built-in into the door, fire-resistant for 60 min.: Type 464/2
- Built-in into wall or ceiling, fire-resistant for 120 min.: Type 467



Air supply through floors or linear bar louvres

Inside a building, air can be supplied or removed through openings in ceilings or walls, but also through the floor or through linear bar louvres in windowsills. Typically, louvres of this type are fitted above heating elements.

- Floor louvre: Type 311
- Linear bar louvre: Types 392, 394

SUPPORT EVERY STEP OF THE WAY

We are here for you (and your team)! Looking for some training? Technical assistance or an intervention at the construction site?

SUPPORT

One phone call to the **HOTLINE** was enough to get my team back on track at the construction site. We promptly got the technical information we were looking for. Perfect service that saved a lot of time!



Hotline

Not sure which solution is the best answer? Struggling with a specific technical issue at the construction site? Contact one of our distribution partners or call a Renson helpdesk representative via the **HOTLINE** on +32 (0)56 30 30 30. If necessary, we will even send a Renson technician to your site. This will save you lots of time and give you a lot less to worry about!

FABRICATOR

Thanks to an extensive network of distributors and local fabricators, even our custom-made louvres can be delivered to you quickly and in the quality you expect. Find a dealer or fabricator in your area via the dealer locator on our website.



Renson Academy

A perfectly functioning ventilation system starts with correct installation. Good product knowledge and technical skills will save you a lot of time. You (and your team) are welcome to join us for:

- An update of your product knowledge
- A refresher of your skills
- Learning new techniques

? FREQUENTLY ASKED QUESTIONS

Find answers to the most frequently asked questions in the FAQ sections of My-Lio or the Renson Ventilation Set-up app. Handy if you want to look something up quickly.

! RENSON.NET

Your customers can find all the information they need about our products on our website. But that's not all: all the technical information you need, such as manuals, technical data sheets, ecolabels, brochures for your customers, specification sheets and much more, is also available online. If you are unable to find what you were looking for right away, contact us on +32 (0)56 30 30 00

! Renson Academy On Tour

Short on time? Too far away? Our Academy is happy to come to you. Need training tailored to your needs? Not a problem! Putting theory straight into practice will help you move forward! We would love to hear how we can support you. Register at: renson.net > Professional/Architect > Aftersales/Service



RENSON'S KEY STRENGTHS

At Renson, we believe high-quality products and innovative solutions contribute to energy-efficient, comfortable and healthy living and working environments. Our slogan 'Creating healthy spaces' reflects this mission, which we achieve by drawing on a number of fundamental principles.

OUR FUNDAMENTAL PRINCIPLES



MINIMALIST DESIGN

We set high standards when it comes to design. Renson solutions offer an architecturally sound solution for every type of building. Detailed finishing and seamless integration help achieve exactly that.



THE POWER OF INNOVATION

Our hunger for innovation is what drives progress. We optimise our solutions by developing and applying innovative technologies.

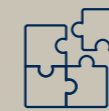

ENDLESS CUSTOMISATION OPTIONS

A high-quality functional building envelope can also offer visual added value. The countless possibilities in terms of colour, shape and finishing give each building the desired unique façade identity.



SUSTAINABLE ENTREPRENEURSHIP

We cannot build a healthy living environment without tending to a healthy world. The recyclability of aluminium and the efficient production of our blades contribute to the sustainable properties of the building envelope.



ULTIMATE INSTALLATION AND EASE OF MAINTENANCE

Our advanced engineering is geared towards ease of use and minimum maintenance. From configuration and ordering to quick and trouble-free installation.

ONLINE PRODUCT SELECTOR

How to choose the right product

DIGITAL TOOLS

Find a suitable product for your project and consult all our available tools and documents, from drawings to calculators for airflow or sound calculation.



Renson.net website

You will find an overview of all products with accompanying technical drawings, specification sheets and leaflets on the [renson.net](https://www.renson.net) website. On this website, you can quickly find the most suitable type for your application, thanks to the extensive searching, filtering and calculating possibilities. You can also download the results of your selection, contact one of our specialists for additional advice, or find a dealer in your area.

SELECTION CRITERIA

This section helps you to select the most suitable Renson louvre. We'll also run you through some commonly used definitions to describe the properties of louvres.



SELECTION CRITERIA

Inside or outside use

Several criteria need to be considered when deciding on the most appropriate louvre. The location where a louvre is used—in the outer shell or inside a building or room—plays a major role in determining which types are suitable. In this brochure, all louvres are broken down into separate groups for outside and inside use.

Outside use

Louvres used in the external shell of a building are often subject to requirements that matter less or not at all for louvres used inside, such as UV resistance, weather resistance, rain resistance, insect resistance, burglar resistance or fall safety.



Inside use

Different requirements often apply to louvres used inside of buildings. Fire resistance, noise reduction or aesthetics are often the most important aspects here.



Installation method

Aside from the functional requirements applicable to louvres, the installation method—how the louvre is fitted into the wall—is another decisive factor in any choice of louvre. Three different options are available in this regard: built-in, surface-mounted and glazed-in.

Built-in

Built-in is the most common installation method. In this situation, the louvre is fitted into an opening in a wall. The result is a nice, flush finish. For this installation method, it is important that the necessary depth is available in the wall and that the opening is the same shape as the louvre. Usually, these louvres come with a flange that hides the installation joint around the louvre and any imperfections at the edge of the opening, and that delivers an optimal seal. But if you prefer perfectly flush integration, a flangeless version is also available for many types. Built-in louvres usually come with installation dowels that allow them to be invisibly fastened from the inside. If this is not possible, these louvres can also be glued or screwed into the wall.



Surface-mounted

Surface mounting is the simplest method. This involves choosing a louvre larger than the opening in the wall and screwing it onto the wall in front of the opening.

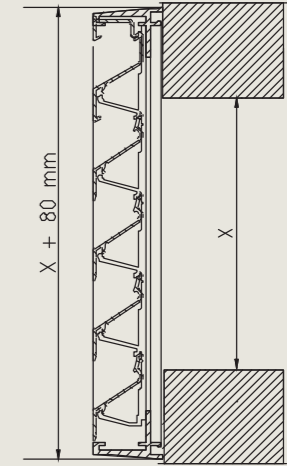
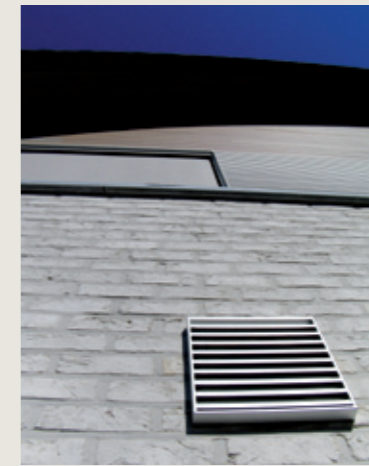

With flange

Glazed-in

Glazed-in louvres, are louvres that can be clamped into a window instead of and just like a pane of glass. This installation method is typically used in curtain walls composed mainly or entirely of stiles, rails and glass or other infill panels.



Without flange

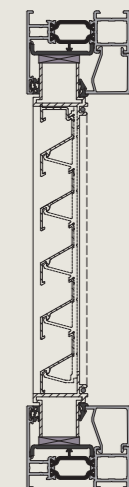

Airflow

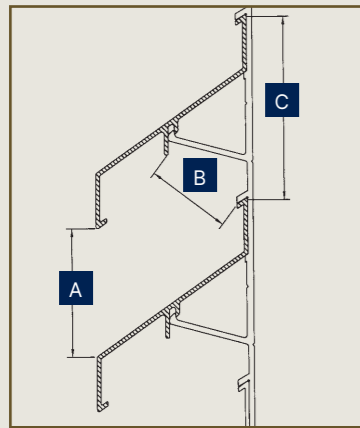

A. Visual distance between two blades
 B. Narrowest gap between two blades
 C. Blade pitch

Geometric terms

Visual free area (*) = the ratio of the visual distance between two blades (A) and the pitch in the blade (C). $VFA = A/C$

Physical free area (*) = the ratio of the smallest opening between two blades (B) and the pitch in the blade (C). Due to the effects of deformation and installation, it is possible that this figure will deviate by no more than 5%. $PFA = B/C$

(*) Calculations do not take into account top and/or bottom blades. All properties of the louvres can be calculated using the free software on our website: www.rensonlouvres.eu.

Air technical terms

K-value = the value describing the aerodynamic resistance against the flow of air. In contrast to the free area, this value describes the ratio between the flow rate through the louvres and the pressure drop across the louvres related to this.

C_e = Entry loss coefficient = the value describing the aerodynamic conductivity of the airflow (when supplying air). This is the ratio of the effective air flow through a louvre compared to the theoretical air flow.

C_d = Discharge loss coefficient = the value describing the aerodynamic conductivity of the airflow (when extracting air). This is the ratio of the effective air flow through a louvre compared to the theoretical air flow. These air technical terms are defined according to EN 13030.

These air technical values are based on louvres measuring 1 m x 1 m. For small dimensions, the real values may differ significantly. As such, for louvres with fewer than six blades, it is advisable to have louvres that are larger than calculated or request custom advice.

c	Airflow rating
$0,400 \leq c$	1
$0,300 \leq c < 0,400$	2
$0,200 \leq c < 0,300$	3
$c < 0,200$	4

Before determining the pressure drop, the air speed must be determined from the following equation:

Flow rate = m^3/s
 Area = m^2
 Air speed = m/s

The volume of air passing through the louvre
 The size of the louvre (front view)
 The speed of the approaching air at the front of the louvre. (This is the result of a certain volume passing through the louvre.)

$$\text{Air speed} = \frac{\text{AIRFLOW}}{\text{SURFACE AREA}} \text{ (a)}$$

If two elements in this equation are known, the third can be calculated.

For determining dimensions, air speeds or pressure drop, the equations can be transposed.

$$\text{Pressure drop} = K \times (0,5 \times \text{air density } 1,2 \text{ kg/m}^3) \times \text{Air speed}^2 \text{ (b)}$$

Relationship between K value and C coefficient:

$$K = \frac{1}{C^2}$$

Group	Louvre type	blade pitch (mm)	Geometric specifications		Aerodynamic specifications					
			Physical free area (%)	Visual free area (%)	Air supply			Air extraction		
					Resistance factor K_e	Flow coefficient C_e	Airflow rating	Resistance factor K_d	Flow coefficient C_d	Airflow rating
Outside/Built-in	411	33.3	50	59	18.9	0.230	3	19.8	0.225	3
	411R	33.3	40	59	22.7	0.210	3	25.3	0.199	4
	412	20	39	93	34.6	0.170	4	34.6	0.170	4
	412R	20	39	93	34.6	0.170	4	34.6	0.170	4
	421	50	49	70	12.1	0.287	3	12.1	0.287	3
	421R	50	47	70	12.1	0.287	3	12.1	0.287	3
	421RC2	50	46	70	12.9	0.278	3	12.2	0.286	3
	421RC3	50	46	70	12.9	0.278	3	12.2	0.286	3
	427	100	53	88	11.4	0.296	3	11.7	0.293	3
	445/86	60	34	75	10.7	0.306	2	10.0	0.316	2
	448D	150	33	65	51.8	0.139	4	51.8	0.139	4
	448/150	150	34	64	16*	0.250	3	21,2*	0.217	3
	448/225	150	34	64	20,3*	0.222	3	23,1*	0.208	3
	448/300	150	34	64	25,8*	0.197	4	27,1*	0.192	4
	449D	170	32	69	39.1	0.160	4	37.2	0.164	4
	449/150	170	37	69	14,6*	0.262	4	19,1*	0.200	4
	449/225	170	37	69	19,1*	0.229	4	21,4*	0.180	4
	450	50	57	70	10,5*	0.309	2	16,5*	0.246	3
	450V	50	57	70	10,7*	0.306	2	16,5*	0.246	3
	452	66	41	70	66.1	0.123	4	79.7	0.112	4
457	75	52	73	13.1	0.276	3	14.2	0.265	3	
458	60	77	85	4.7	0.462	1	4.8	0.457	1	
468SA	85	29	29	115.6	0.093	4	115.6	0.093	4	
480	60	76	90	4.6	0.466	1	5.2	0.439	1	
481	50	60	70	8.2	0.349	2	9.8	0.319	2	
491	33.3	26	56	123.5	0.090	4	118.1	0.092	4	
Outside/Glazed-in	414	33.3	50	59	18.9	0.230	3	19.8	0.225	3
	414R	33.3	40	59	22.7	0.210	3	25.3	0.199	4
	415	20	39	93	34.6	0.170	4	34.6	0.170	4
	415R	20	39	93	34.6	0.170	4	34.6	0.170	4
	424	50	49	70	12.1	0.287	3	12.1	0.287	3
	424RC2	50	46	70	12.9	0.278	3	12.2	0.286	3
	427GL	100	53	88	11.4	0.296	3	11.7	0.293	3
	483	60	76	90	4.6	0.466	1	5.2	0.439	1
	484	50	60	70	8.2	0.349	2	9.8	0.319	2
Outside/Surface-mounted	494	33.3	26	56	123.5	0.090	4	118.1	0.092	4
	431	33.3	50	59	18.9	0.230	3	19.8	0.225	3
	431R	33.3	40	59	22.7	0.210	3	25.3	0.199	4
	431RC2	33.3	40	59	22.7	0.210	3	25.3	0.199	4
Inside/Wall/Ceiling	432	33.3	50	59	18.9	0.230	3	19.8	0.225	3
	441	-	25	-	30.1	0.182	4	30.1	0.182	4
	464/1-Incendo	20	51	61	10.3	0.312	2	10.3	0.312	2
Inside/Door	467	18	67	67	4.2	0.490	1	4.1	0.496	1
	461	20	39	93	34.6	0.170	4	34.6	0.170	4
	461AK-Silendo	n/a	n/a	n/a	n/a	n/a	n/a	n/a	n/a	n/a
Floor and linear bar louvres	464/2-Incendo	20	51	61	10.3	0.312	2	10.3	0.312	2
	311	16.5	76	76	-	-	-	-	-	-
	392	13	76	76	5.71	0.419	1	5.71	0.419	1
394	16.5	59	59	-	-	-	-	-	-	

u/a: Unavailable

n/a: Not applicable

Using the K value method

METHOD 1: Determine the type of louvre suitable for a certain opening

1. Determine the desired flow rate
2. Determine the available opening (size of continuous louvre)
3. Determine the maximum allowable pressure drop
4. Choose the suitable louvre type based on the K value

Method 1 example

Which type of louvre is suitable to achieve the desired ventilation volume of 5500 m³/h with a maximum pressure drop of 25 Pa and an opening of 1 m²?

Calculation:

Calculation formula (a)

Flow rate = 5500 / 3600 = 1.53 m³/s

Louvre size = 1 m²

$$\text{Air speed} = 1.53 \text{ m}^3/\text{s} / 1 \text{ m}^2 \\ (\text{surface area}) = 1.53 \text{ m/s}$$

Calculation formula (b) Pressure drop = 25 Pa

Air speed = 1.53 m/s

$$\text{K factor} = 25 / (0.6 \times 1.53^2) = 17.80$$

This is the maximum K value to achieve the desired volume at a certain pressure drop and size. All blade types with a K factor less than or equal to 17.80 can be used in this situation.

METHOD 2: Determine the dimensions of the opening for a particular type of louvre

1. Choose the louvre type
2. Determine the air speed at the front of the louvre using the K value and the maximum pressure drop
3. Determine the desired flow rate
4. Determine the minimum dimensions of the louvre

Method 2 example

The architect prefers a Type 421 louvre. What size is needed to have a maximum pressure drop of 30 Pa at a given flow rate of 10,000 m³/h?

Calculation:

Calculation formula (b)

K 421 = 12.10

$$\text{Air speed} = \sqrt{\frac{30}{0.6 \times 12.10}} = 2.03 \text{ m/s}$$

Calculation formula (a) Flow rate = 10,000 / 3,600 = 2.78 m³/s

$$\text{Surface area} = \frac{2.78 \text{ m}^3/\text{s}}{2.03 \text{ m/s}} = 1.37 \text{ m}^2$$

This is the minimum required area of the Type 421 louvre to achieve a pressure drop lower than 30 Pa at a flow rate of 10,000 m³/h.



Rain resistance

Principle

Renson louvres have been tested by BSRIA, the Building Services Research and Information Association, according to EN 13030:2001. During this test, a louvre of 1m² was tested with a driving rain capacity of 75 litres/hour and a wind speed of 13 m/s. Based on the results achieved, i.e. the amount of water ingress behind the louvre, a rating was assigned.

This rating is determined at different supply speeds, ranging from 0 to a maximum of 4 m/s. At higher speeds, the chance of water being sucked in is greater, and the rating is usually lower.

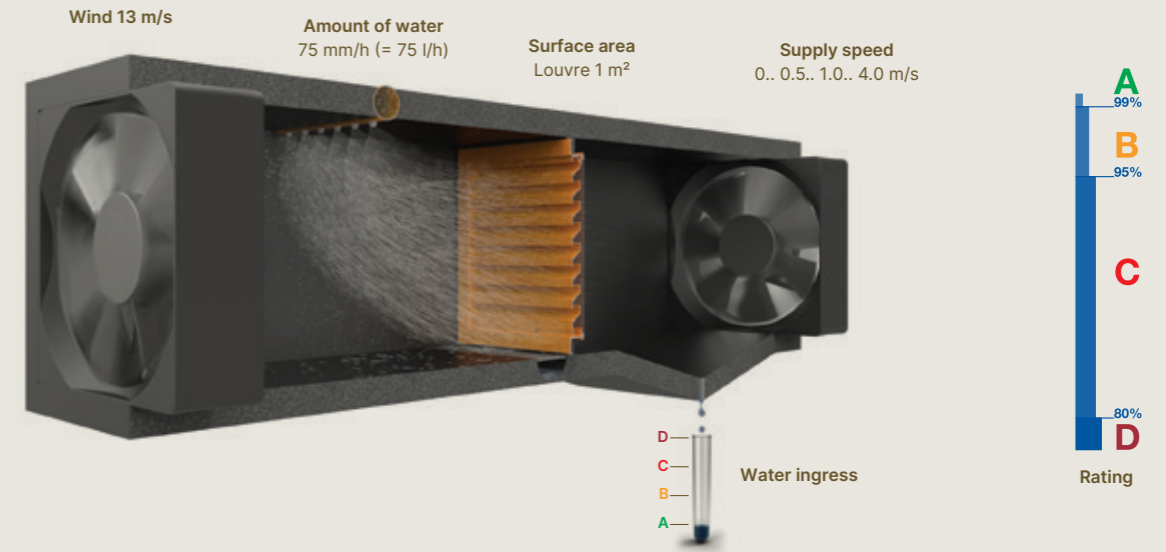

Group		Louvre type		Blade pitch (mm)		Mesh type (mm)		Water resistance																													
								With mesh and water channel														Without water channel															
								0.0 m/s		0.5 m/s		1.0 m/s		1.5 m/s		2.0 m/s		2.5 m/s		3.0 m/s		3.5 m/s		0.0 m/s		0.5 m/s		1.0 m/s		1.5 m/s		2.0 m/s		2.5 m/s		3.0 m/s	
Rating	%	Rating	%	Rating	%	Rating	%	Rating	%	Rating	%	Rating	%	Rating	%	Rating	%	Rating	%	Rating	%	Rating	%	Rating	%	Rating	%	Rating	%	Rating	%						
Outside/Built-in	411	33.3	2 × 2	A	99.5	A	99.0	B	96.5	D	78.9	D	41.9	D	23.6			D	15.2	D	10.4	B	95.3	C	91.0	C	80.5	D	46.6	D	22.0	D	7.4	D	7.3	D	7.5
	411R	33.3	2 × 2	-	-	-	-	-	-	-	-	-	-	-	-			-	-	-	-	A	99.6	A	99.1	B	97.3	C	84.2	D	50.0	D	24.5	D	15.4	D	13.4
	412	20	2 × 2	A	99.9	A	99.7	A	99.2	B	95.6	C	87.5	D	63.1			-	-	-	-	C	90.4	C	81.6	D	68.8	D	40.4	-	-	-	-	-	-	-	-
	412R	20	2 × 2	-	-	-	-	-	-	-	-	-	-	-	-			-	-	-	-	C	90.4	C	81.6	D	68.8	D	40.4	-	-	-	-	-	-	-	-
	421	50	2 × 2	B	95.0	C	92.2	C	89.8	C	84.5	D	72.6	D	56.7			D	44.4	D	33.7	C	91.4	C	86.2	D	78.9	D	65.8	D	45.3	D	26.4	D	13.7	D	1.8
	445/86	60	2 × 2	B	98.0	B	95.2	C	89.9	D	76.7	D	47.6	D	20.0			D	15.4	D	8.3	C	83.3	D	73.5	D	63.2	D	50.6	D	37.6	D	28.5	D	23.5	D	20.2
	448D	150	6 × 6	-	-	-	-	-	-	-	-	-	-	-	-			-	-	-	-	A	99.0	B	98.3	B	97.1	C	91.4	D	68.4	D	46.4	D	32.8	D	17.8
	448/150	150	2 × 2	-	-	-	-	-	-	-	-	-	-	-	-			-	-	-	-	B	96.7	C	91.3	C	84.6	D	72.4	D	53.0	D	42.4	D	37.0	D	17.9
	448/225	150	2 × 2	-	-	-	-	-	-	-	-	-	-	-	-			-	-	-	-	C	94.8	C	86.2	D	78.8	D	69.1	D	56.7	D	37.0	D	17.6	D	14.5
	448/300	150	2 × 2	-	-	-	-	-	-	-	-	-	-	-	-			-	-	-	-	C	91.2	C	80.4	D	71.3	D	61.6	D	50.0	D	33.3	D	17.5	D	10.8
	449D	170	6 × 6	-	-	-	-	-	-	-	-	-	-	-	-			-	-	-	-	B	96.9	B	95.6	C	93.7	C	87.1	D	72.8	D	45.9	D	30.9	D	28.4
	449/150	170	2 × 2	-	-	-	-	-	-	-	-	-	-	-	-			-	-	-	-	C	88.0	D	78.5	D	71.1	D	62.4	D	53.6	D	40.4	D	29.9	D	18.2
	449/225	170	2 × 2	-	-	-	-	-	-	-	-	-	-	-	-			-	-	-	-	C	93.2	C	84.9	D	78.6	D	71.0	D	61.7	D	50.6	D	26.5	D	19.8
	450	50	2 × 2	A	100.0	A	100.0	A	100.0	A	100.0	A	99.9	A	99.9			A	99.2	C	92.2	A	99.5	A	99.4	A	99.7	A	99.8	A	99.8	A	99.2	B	96.6	C	79.1
	450V	50	2 × 2	A	100.0	A	99.9	A	99.9	A	99.9	A	99.5	A	99.6			A	99.7	A	99.5	-	-	-	-	-	-	-	-	-	-	-	-	-	-	-	
	452	66	6 × 6	A	100.0	A	99.9	A	99.6	B	95.0	D	56.9	D	28.3			D	11.6	-	-	-	-	-	-	-	-	-	-	-	-	-	-	-	-	-	
457	75	2 × 2	B	96.9	B	95.2	C	93.7	C	89.2	D	79.9	D	66.5			D	48.5	D	36.0	C	90.4	C	87.3	C	84.8	C	81.3	D	73.9	D	54.9	D	37.7	D	15.5	
480	60	2 × 2	C	90.1	C	87.3	C	84.2	C	80.1	D	73.4	D	62.0			-	-	-	-	D	75.9	D	68.9	D	62.8	D	56.9	D	51.7	D	45.5	D	39.4	D	30.4	
481	50	2 × 2	B	96.0	C	94.3	C	92.2	C	88.2	D	76.9	D	57.3			D	42.4	D	33.0	C	90.6	C	86.4	C	80.8	D	72.0	D	51.4	D	31.8	D	22.0	D	13.7	
491	33.3	6 × 6	A	100.0	A	99.7	C	91.6	D	50.1	D	16.9	D	14.7			D	15.4	-	-	-	-	-	-	-	-	-	-	-	-	-	-	-	-	-		
Outside/Window	414	33.3	2 × 2	A	99.5	A	99.0	B	96.5	D	78.9	D	41.9	D	23.6			D	15.2	D	10.4	B	95.3	C	91.0	C	80.5	D	46.6	D	22.0	D	7.4	D	7.3	D	7.5
	414R	33.3	2 × 2	-	-	-	-	-	-	-	-	-	-	-			-	-	-	-	A	99.6	A	99.1	B	97.3	C	84.2	D	50.0	D	24.5	D	15.4	D	13.4	
	415	20	2 × 2	A	99.9	A	99.7	A	99.2	B	95.6	C	87.5	D	63.1			-	-	-	-	C	90.4	C	81.6	D	68.8	D	40.4	-	-	-	-	-	-	-	-
	424	50	2 × 2	B	95.0	C	92.2	C	89.8	C	84.5	D	72.6	D	56.7			D	44.4	D	33.7	C	91.4	C	86.2	D	78.9	D	65.8	D	45.3	D	26.4	D	13.7	D	1.8
	483	60	2 × 2	C	90.1	C	87.3	C	84.2	C	80.1	D	73.4	D	62.0			-	-	-	-	D	75.9	D	68.9	D	62.8	D	56.9	D	51.7	D	45.5	D	39.4	D	30.4
	484	50	2 × 2	B	96.0	C	94.3	C	92.2	C	88.2	D	76.9	D	57.3			D	42.4	D	33.0	C	90.6	C	86.4	C	80.8	D	72.0	D	51.4	D	31.8	D	22.0	D	13.7
Outside/Surface mounted	431	33.3	2 × 2	A	99.5	A	99.0	B	96.5	D	78.9	D	41.9	D	23.6			D	15.2	D	10.4	B	95.3	C	91.0	C	80.5	D	46.6	D	22.0	D	7.4	D	7.3	D	7.5
	431R	33.3	2 × 2	-	-	-	-	-	-	-	-	-	-	-			-	-	-	-	A	99.6	A	99.1	B	97.3	C	84.2	D	50.0	D	24.5	D	15.4	D	13.4	
	431RC2	-	-	-	-	-	-	-	-	-	-	-	-	-			-	-	-	-	A	99.6	A	99.1	B	97.3	C	84.2	D	50.0	D	24.5	D	15.4	D	13.4	
	432	33.3	2 × 2	A	99.5	A	99.0	B	96.5	D	78.9	D	41.9	D	23.6			D	15.2	D	10.4	B	95.3	C	91.0	C	80.5	D	46.6	D	22.0	D	7.4	D	7.3	D	7.5

Noise reduction

Sound technical terms

- dB(a) = a decibel (dB) rating is used in this brochure to determine the reduction in sound level for a louvre with acoustic properties. The A weighting (dB(a)) takes the sensitivity of the human ear to pitches of sounds into account.
- $D_{n,e,w}$ = weighted normalised sound insulation of a small opening such as a gap or crack.
- $R_w (C;C_{tr})$ = the weighted sound reduction index expresses the weighted difference (dB) between the indoor and outdoor sounds through a wall, which consists of a combination of various elements such as brick walls, glazing, wall louvres, etc.
- C = spectrum correction for pink noise (high frequencies), added up for R_w or $D_{n,e,w}$ when the noise source is speeding traffic, for example.
- C_{tr} = spectrum correction (Ctraffic) for traffic noises (low frequencies), added up for R_w or $D_{n,e,w}$ when the noise source is city traffic, for example.
- Frequency = pitch expressed in Hertz (Hz), number of vibrations per second.

Louvre type	R_w dB(A)	$D_{n,e,w}$ dB(A)	C dB(A)	C_{tr} dB(A)
445/86	6	-	-1	-2
448/150	11	-	0	-2
448/225	16	-	-1	-4
448/300	18	-	-1	-5
449/150	10	-	0	-1
449/225	14	-	-1	-3
468AK1	8	-	-1	-2
461AK - Silendo	-	32	0	-2
468AK2	8	-	-1	-2
469 - Invisido	-	28	-1	0

IP ratings

- **IP rating** = international protection rating, protection level against the intrusion of foreign objects and water. The IP rating consists of two figures: the first one indicates the level of protection against physical contact and the intrusion of foreign objects; the second is the level of protection against moisture. Additionally, a letter can indicate which protection is offered against physical contact with hazardous objects by people within the housing (electrical enclosures). The distance to the electrical installation is measured from the outer surface area of the louvres. The IP rating of the louvres is determined in accordance with EN 60529.
- **Definition of IP2XD**:- 2: Protection against medium-sized objects/approach by fingers. Protection against the intrusion of medium-sized objects (larger than 12.5 mm)–X: Protection against moisture is not verified according to this standard given that the louvres are tested according to the more accurate water-resistance test for louvres according to EN 13030. –D: Protection against contact with wire (Ø 1 mm, length 100 mm)
- **Definition of IP44**:- 4: Protection against sharp objects/contact with a tool/wire. Protection against the intrusion of fixed objects larger than 1 mm. - 4: Splash-proof: protected from water spray from any direction (10 l/min.).

Louvre type	With mesh and water channel	with mesh and water channel–min. distance to electrical installation	without water channel	without water channel–min. distance to electrical installation
411	IP23D	32 cm	IP23D	33 cm
411R	-	-	IP2XD	10 cm
412	IP44	35 cm	IP2XD	-
412R	IP2XD	-	IP2XD	-
421	IP2XD	10 cm	IP2XD	10 cm
421R	IP2XD	10 cm	IP2XD	10 cm
421RC2	IP23D	20 cm	IP2XD	10 cm
421RC3	IP23D	20 cm	IP2XD	10 cm
448D	IP2XD	10 cm	IP2XD	10 cm
449/225	IP2XD	-	IP2XD	-
449D	IP2XD	10 cm	IP2XD	10 cm
450	IP44	-	IP2XD	-
450V	-	-	-	-
452	IP44	25 cm	IP2XD	-
457	-	-	-	-
458	-	-	-	-
468SA	IP2XD	-	IP2XD	-
480	IP2XD	18 cm	-	-
481	IP2XD	10,5 cm	-	-
491	IP44	15 cm	-	-
414	IP23D	32 cm	IP23D	33 cm
414R	-	-	IP2XD	10 cm
415	IP44	35 cm	IP2XD	-
415R	IP2XD	-	IP2XD	-
424	IP2XD	10 cm	IP2XD	10 cm
424RC2	IP23D	20 cm	IP2XD	10 cm
427GL	-	-	-	-
483	IP2XD	18 cm	-	-
484	IP2XD	10,5 cm	-	-
494	IP44	15 cm	-	-
431	IP23D	32 cm	IP23D	33 cm
431R	-	-	IP2XD	10 cm
431RC2	-	-	-	-
432	IP23D	32 cm	IP23D	33 cm

QUALITY & TESTS

The following independent test certificates are available for most louvres:

- **Airflow and water repellence**

- Applicable standard:
 - » EN 13030:2001
- Independent test lab: BSRIA



- **Soundproofing**

- Applicable standards:
 - » EN ISO 140-1:1997+A1:2004, EN 20140-3:1995+A1:2004
 - » EN ISO 717-1:1996+A1:2006
- Independent test labs: IFT – Peutz



- **IP rating**

- Applicable standard:
 - » EN 60529: 1991 – A1: 2000 – A2: 2013
- Independent test lab: Blue Guide EMC Lab



- **Burglar resistance**

- Applicable standard:
 - » EN 1627-1630: 2021
- Independent test labs: IFT – Buildwise (formerly BBRI)

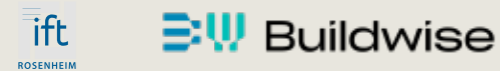

- **Fall prevention**

- Applicable standards:
 - » Germany: ETB guideline 'Bauteile die gegen Absturz sichern'
 - » UK: BS 6180: 2011
 - » Other: EN 13049: 2003
- Independent test labs: EPH – (Wintech by) UL – Buildwise (formerly BBRI)



- **Fire resistance**

- Applicable standard:
 - » EN 13501-2: 2006 / ETAG 026-4:2008
- Independent test lab: Warringtonfire Ghent



BUILT-IN LOUVRES FOR OUTSIDE APPLICATIONS



411

Aluminium rain-resistant built-in louvre with 50% free area, Class A3

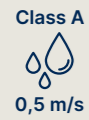

Material properties		Standard version	
Material	Aluminium, alloy EN AW-6063 T66		
Standard mesh type	Stainless steel 304 - 2.3 x 2.3 mm		
Surface treatment	Anodisation (20 microns), chemically etched F1-E6 natural colour	Polyester powder coating (60-80 micron) Seaside quality A & Standard powders	
Wall bracket type	no. 418 (included)		
Dimensions			
Blade pitch	33.3 mm		
Recess depth	29 mm		
Flange	21 mm		
Minimum dimensions (W x H)	100 x 100 mm		
Maximum width	4,000 mm		
Maximum height	4,000 mm		
Width and height cannot both exceed 2000 mm			
Maximum louvre surface area	8 m ²		

Our louvres come in a variety of dimensions, all of which can be used across most applications. When using large sizes in high-stress environments, such as at great heights, it is advisable to additionally verify the stability of the louvres and their mounting.

Performance								
Airflow rate								
Physical free area		50%						
Visual free area		59%						
Air supply	Resistance factor K	18.9						
	Flow coefficient C	0.230						
	Airflow rating	3						
Air extraction	Resistance factor K	19.8						
	Flow coefficient C	0.225						
	Airflow rating	3						
IP rating								
With mesh and water channel		IP23D (32 cm)*						
Without water channel		IP23D (33 cm)*						
Water resistance %								
at (m/s)	0.0	0.5	1.0	1.5	2.0	2.5	3.0	3.5
With 2 x 2 mesh and water channel	A	A	B	D	D	D	D	D
	99.5	99.0	96.5	78.9	41.9	23.6	15.2	10.4
Without water channel	B	C	C	D	D	D	D	D
	95.3	91.0	80.5	46.6	22.0	7.4	7.3	7.5

*Min. distance to electrical installation

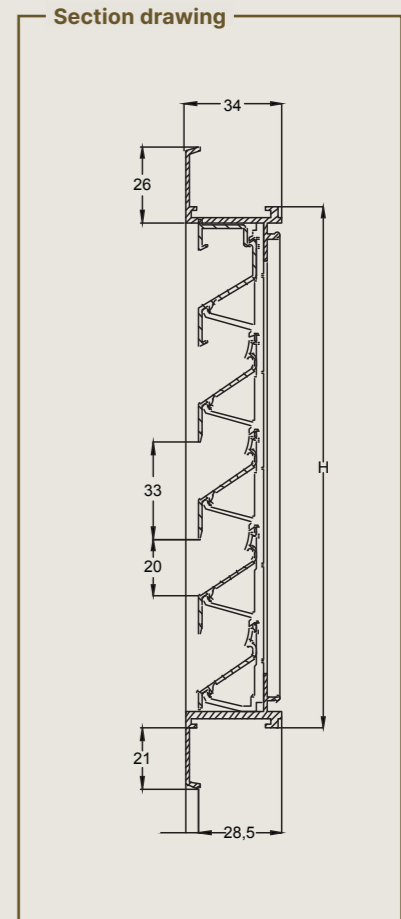

OUTSIDE
BUILT-IN

Available options

- Counterframe:** Narrow counterframe for panel thicknesses from 23 mm to 45 mm
Deep counterframe for panel thicknesses from 46 mm to 71 mm
- Mounting method:** Long dowels no. 418L / Clip springs no. 419 / Screw holes in flange frame
- Custom flange:** Full surround or partial, with or without shortened flange
- Closable:** With sliding vent
- Operation:** Slider / Rotary knob / Cord / Rod / Linear actuator (230V or 24V)
- Thermally insulated:** Sandwich panel on back, with or without opening for air duct connection
- Finish:** Anodised: layer thickness 25 microns / other colours / other textures (E1-E10)
Powder coating: pre-treatment in accordance with Seaside OX (pre-anodisation) / non-standard powders
- Other mesh types:** Mesh sizes 2.3 mm x 2.3 mm, 6 mm x 6 mm, 10 mm x 10 mm or 20 mm x 20 mm /
Stainless steel grade AISI304 or AISI316 / No mesh
- Special shapes / Water channel / Removable mesh / Filter / Drainage blade / Joining**
- Fitted with an earth terminal**

Stock models							
Dimensions (W x H) mm	Natural colour anodised F1	Renson Standard white	STR 7016	STR 9005	flow rate at 2 Pa (m ³ /h)	flow rate at 10 Pa (m ³ /h)	flow rate at 20 Pa (m ³ /h)
200 × 200	9085	11969	10460	9131	50	111.8	158.1
300 × 200	17361	-	-	-	77	172.2	243.5
300 × 300	10427	-	-	-	118	263.9	373.1
400 × 200	17362	9132	-	-	103	230.3	325.7
400 × 300	10428	17395	-	-	159	355.5	502.8
400 × 400	9086	9133	-	-	215	480.8	679.9
500 × 300	9087	-	-	-	201	449.4	635.5
500 × 400	10429	-	-	-	271	606	857
500 × 500	11926	-	-	-	342	764.7	1081.5
600 × 300	11927	-	-	-	242	541.1	765.3
600 × 400	9088	-	-	-	327	731.2	1034.1
600 × 600	17363	-	-	-	497	1111.3	1571.7
700 × 700	17364	-	-	-	682	1525	2156.7
1000 × 500	17393	-	-	-	694	1551.8	2194.6
1000 × 1000	11925	-	-	-	1409	3150.6	4455.6



411R

Round aluminium rain-resistant built-in louvre with 40% free area, Class A3



Performance								
Airflow rate								
Physical free area		40%						
Visual free area		59%						
Air supply	Resistance factor K	22.7						
	Flow coefficient C	0.210						
	Airflow rating	3						
Air extraction	Resistance factor K	25.3						
	Flow coefficient C	0.199						
	Airflow rating	4						
IP rating								
IP2XD (10 cm)*								
Water resistance %								
at (m/s)	0.0	0.5	1.0	1.5	2.0	2.5	3.0	3.5
Without water channel	A	A	B	C	D	D	D	D
	99.6	99.1	97.3	84.2	50.0	24.5	15.4	13.4

*Min. distance to electrical installation

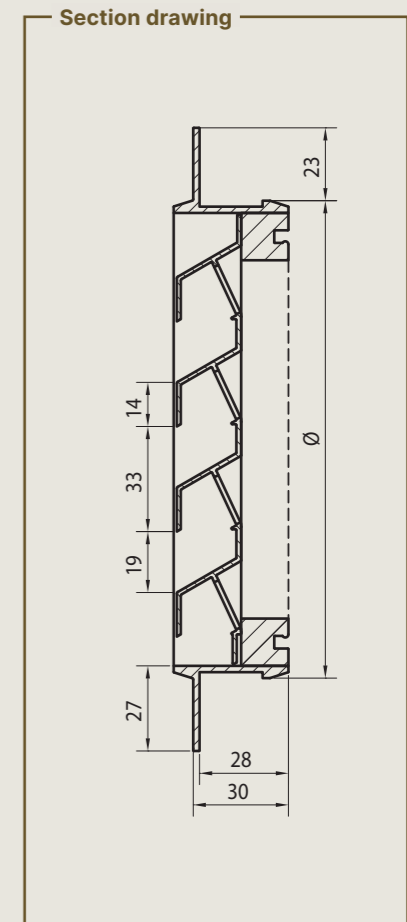

OUTSIDE
BUILT-IN

Material properties	Standard version	
Material	Aluminium, alloy EN AW-6063 T66	
Standard mesh type	Stainless steel 304 - 2.3 × 2.3 mm	
Surface treatment	Anodisation (20 microns), chemically etched F1-E6 natural colour	Polyester powder coating (60-80 micron) Seaside quality A & Standard powders
Wall bracket type	Pre-assembled	
Dimensions		
Blade pitch	33.3 mm	
Recess depth	28 mm	
Flange	23 mm	
Minimum diameter	300 mm	
Maximum diameter	1500 mm	

Our louvres come in a variety of dimensions, all of which can be used across most applications. When using large sizes in high-stress environments, such as at great heights, it is advisable to additionally verify the stability of the louvres and their mounting.

Available options

- **Custom flange:** Without flange
- **Thermally insulated:** Sandwich panel on back, with or without opening for air duct connection
- **Finish:** Anodised: layer thickness 25 microns / other colours / other textures (E1-E10)
Powder coating: pre-treatment in accordance with Seaside OX (pre-anodisation) / non-standard powders
- **Other mesh types:** Mesh sizes 2.3 mm x 2.3 mm, 6 mm x 6 mm, 10 mm x 10 mm or 20 mm x 20 mm / Stainless steel grade AISI304 or AISI316 / No mesh

412

Aluminium stick-proof built-in louvre with 39% free area, Class A4-IP44



Material properties		Standard version	
Material	Aluminium, alloy EN AW-6063 T66		
Standard mesh type	Stainless steel 304 - 6 x 6 mm		
Surface treatment	Anodisation (20 microns), chemically etched F1-E6 natural colour	Polyester powder coating (60-80 micron) Seaside quality A & Standard powders	
Wall bracket type	no. 418 (included)		
Dimensions			
Blade pitch	20 mm		
Recess depth	29 mm		
Flange	21 mm		
Minimum dimensions (W x H)	100 x 100 mm		
Maximum width	4000 mm		
Maximum height	4000 mm		
Width and height cannot both exceed 2000 mm			
Maximum louvre surface area	6.7 m ²		

Our louvres come in a variety of dimensions, all of which can be used across most applications. When using large sizes in high-stress environments, such as at great heights, it is advisable to additionally verify the stability of the louvres and their mounting.

Performance								
Airflow rate								
Physical free area		39%						
Visual free area		93%						
Air supply	Resistance factor K	34.6						
	Flow coefficient C	0.170						
	Airflow rating	4						
Air extraction	Resistance factor K	34.6						
	Flow coefficient C	0.170						
	Airflow rating	4						
IP rating								
With mesh and water channel		IP44 (35 cm)*						
Without water channel		IP2XD						
Water resistance %								
at (m/s)	0.0	0.5	1.0	1.5	2.0	2.5	3.0	3.5
With 2 x 2 mesh and water channel	A	A	A	B	C	D	-	-
	99.9	99.7	99.2	95.6	87.5	63.1	-	-
Without water channel	C	C	D	D	-	-	-	-
	90.4	81.6	68.8	40.4	-	-	-	-

*Min. distance to electrical installation

Stock models				
Dimensions (W x H) mm	Natural colour anodised F1	Flow rate at 2 Pa (m ³ /h)	Flow rate at 10 Pa (m ³ /h)	Flow rate at 20 Pa (m ³ /h)
200 x 200	11929	45	100.6	142.3
300 x 300	9089	102	228.1	322.6
400 x 300	9090	136	304.1	430.1
500 x 300	11930	170	380.1	537.6
600 x 400	9090	271	606	857

Available options

- Counterframe:** Narrow counterframe for panel thicknesses from 23 mm to 45 mm
Deep counterframe for panel thicknesses from 46 mm to 71 mm
- Mounting method:** Long dowels no. 418L / Clip springs no. 419 / Screw holes in flange frame
- Custom flange:** Full surround or partial, with or without shortened flange
- Closable:** With sliding vent
- Operation:** Slider / Rotary knob / Cord / Rod / Linear actuator (230V or 24V)
- Thermally insulated:** Sandwich panel on back, with or without opening for air duct connection
- Finish:** Anodised: layer thickness 25 microns / other colours / other textures (E1-E10)
Powder coating: pre-treatment in accordance with Seaside OX (pre-anodisation) / non-standard powders
- Other mesh types:** Mesh sizes 2.3 mm x 2.3 mm, 6 mm x 6 mm, 10 mm x 10 mm or 20 mm x 20 mm / Stainless steel grade AISI304 or AISI316 / No mesh
- Special shapes / Water channel / Removable mesh / Filter / Drainage blade / Joining**

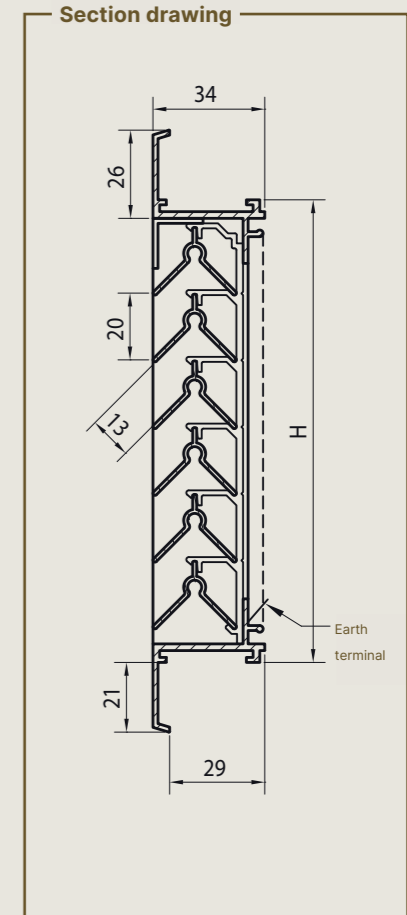

OUTSIDE
BUILT-IN

412R

Round aluminium stick-proof built-in louvre with 39% free area, Class A4

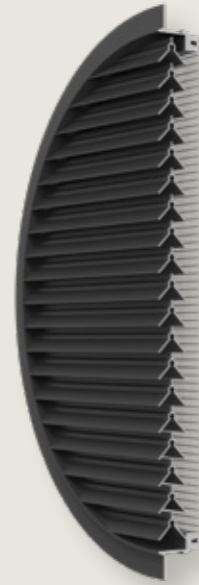

Material properties		Standard version	
Material	Aluminium, alloy EN AW-6063 T66		
Standard mesh type	Stainless steel 304 - 6 × 6 mm		
Surface treatment	Anodisation (20 microns), chemically etched F1-E6 natural colour	Polyester powder coating (60-80 micron) Seaside quality A & Standard powders	
Wall bracket type	Pre-assembled		
Dimensions			
Blade pitch	20 mm		
Recess depth	34 mm		
Flange	23 mm		
Minimum diameter	300 mm		
Maximum diameter	1500 mm		

Our louvres come in a variety of dimensions, all of which can be used across most applications. When using large sizes in high-stress environments, such as at great heights, it is advisable to additionally verify the stability of the louvres and their mounting.

Performance								
Airflow rate								
Physical free area		39%						
Visual free area		93%						
Air supply	Resistance factor K	34.6						
	Flow coefficient C	0.170						
	Airflow rating	4						
Air extraction	Resistance factor K	34.6						
	Flow coefficient C	0.170						
	Airflow rating	4						
IP rating								
IP2XD								
Water resistance %								
at (m/s)	0.0	0.5	1.0	1.5	2.0	2.5	3.0	3.5
Without water channel	C	C	D	D	-	-	-	-
	90.4	81.6	68.8	40.4	-	-	-	-

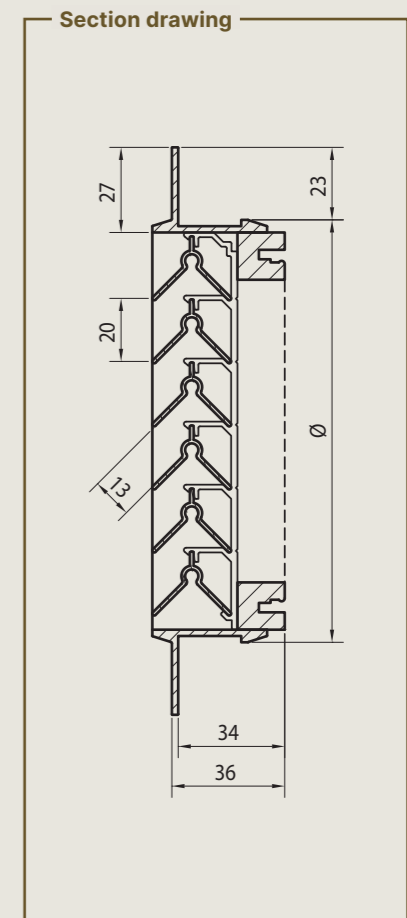

OUTSIDE
BUILT-IN

Available options

- **Custom flange:** Without flange
- **Thermally insulated:** Sandwich panel on back, with or without opening for air duct connection
- **Finish:** Anodised: layer thickness 25 microns / other colours / other textures (E1-E10)
Powder coating: pre-treatment in accordance with Seaside OX (pre-anodisation) / non-standard powders
- **Other mesh types:** Mesh sizes 2.3 mm x 2.3 mm, 6 mm x 6 mm, 10 mm x 10 mm or 20 mm x 20 mm / Stainless steel grade AISI304 or AISI316 / No mesh

421

Aluminium built-in louvre with 49% free area, Class B3



Performance								
Airflow rate								
Physical free area	49%							
Visual free area	70%							
Air supply	Resistance factor K	12.1						
	Flow coefficient C	0.287						
	Airflow rating	3						
Air extraction	Resistance factor K	12.1						
	Flow coefficient C	0.287						
	Airflow rating	3						
IP rating								
With mesh and water channel	IP2XD (10 cm)*							
Without water channel	IP2XD (10 cm)*							
Water resistance %								
at (m/s)	0.0	0.5	1.0	1.5	2.0	2.5	3.0	3.5
With 2 x 2 mesh and water channel	B	C	C	C	D	D	D	D
	95.0	92.0	89.8	84.5	72.6	56.7	44.4	33.7
Without water channel	C	C	D	D	D	D	D	D
	91.4	86.2	78.9	65.8	45.3	26.4	13.7	1.8

*Min. distance to electrical installation

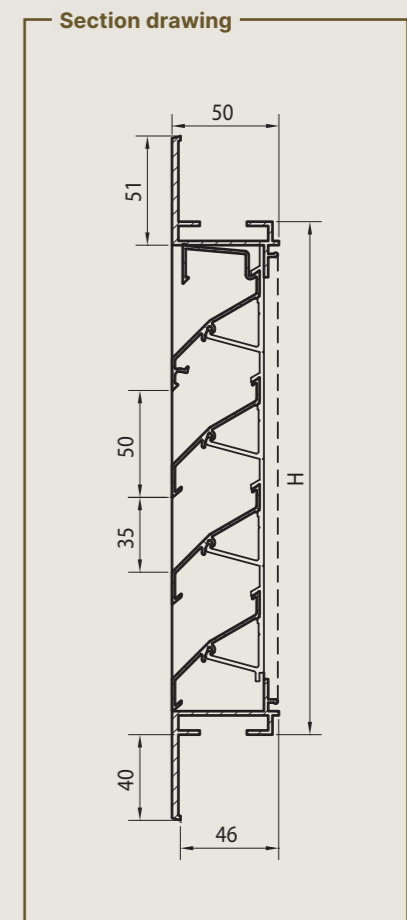

OUTSIDE
BUILT-IN

Material properties	Standard version	
Material	Aluminium, alloy EN AW-6063 T66	
Standard mesh type	Stainless steel 304 - 2.3 x 2.3 mm	
Surface treatment	Anodisation (20 microns), chemically etched F1-E6 natural colour	Polyester powder coating (60-80 micron) Seaside quality A & Standard powders
Wall bracket type	no. 1428 (included)	
Dimensions		
Blade pitch	50 mm	
Recess depth	46 mm	
Flange	40 mm	
Minimum dimensions (W x H)	150 x 150 mm	
Maximum width	4000 mm	
Maximum height	4000 mm	
Width and height cannot both exceed 2000 mm		
Maximum louvre surface area	6 m ²	

Our louvres come in a variety of dimensions, all of which can be used across most applications. When using large sizes in high-stress environments, such as at great heights, it is advisable to additionally verify the stability of the louvres and their mounting.

Available options

- Counterframe:** Narrow counterframe for panel thicknesses from 23 mm to 45 mm
Deep counterframe for panel thicknesses from 46 mm to 71 mm
- Mounting method:** Screw holes in flange frame
- Custom flange:** Full surround or partial, with or without shortened flange
- Closable:** With sliding vent
- Operation:** Slider / Rotary knob / Cord / Rod / Linear actuator (230V or 24V)
- Thermally insulated:** Sandwich panel on back, with or without opening for air duct connection
- Finish:** Anodised: layer thickness 25 microns / other colours / other textures (E1-E10)
Powder coating: pre-treatment in accordance with Seaside OX (pre-anodisation) / non-standard powders
- Other mesh types:** Mesh sizes 2.3 mm x 2.3 mm, 6 mm x 6 mm, 10 mm x 10 mm or 20 mm x 20 mm / Stainless steel grade AISI304 or AISI316 / No mesh
- Special shapes / Water channel / Removable mesh / Filter / Drainage blade / Joining**

421R

Round aluminium built-in louvre with 47% free area

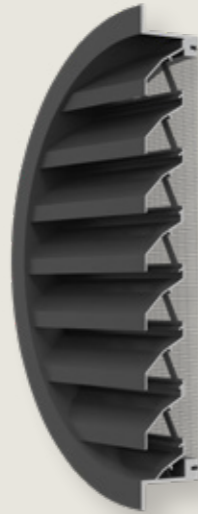

Performance		
Airflow rate		
Physical free area		47%
Visual free area		70%
Air supply	Resistance factor K	12.1
	Flow coefficient C	0.287
	Airflow rating	3
Air extraction	Resistance factor K	12.1
	Flow coefficient C	0.287
	Airflow rating	3
IP rating		
IP2XD (10 cm)*		

*Min. distance to electrical installation

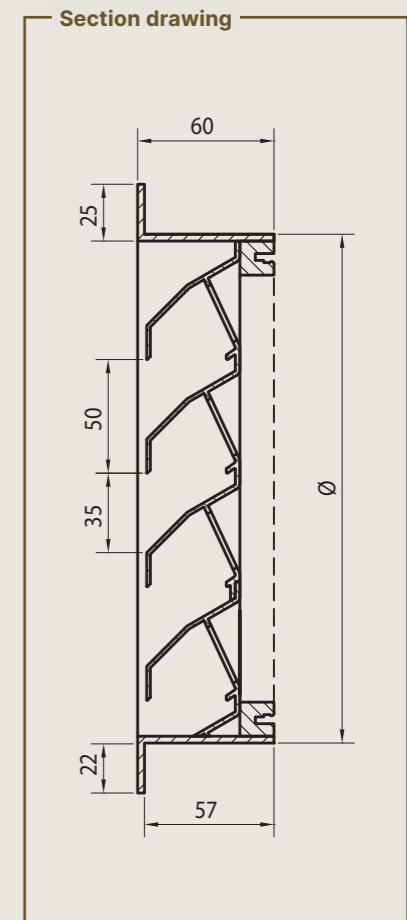

OUTSIDE
BUILT-IN

Material properties	Standard version	
Material	Aluminium, alloy EN AW-6063 T66	
Standard mesh type	Stainless steel 304 - 2.3 × 2.3 mm	
Surface treatment	Anodisation (20 microns), chemically etched F1-E6 natural colour	Polyester powder coating (60-80 micron) Seaside quality A & Standard powders
Wall bracket type	Pre-assembled	
Dimensions		
Blade pitch	50 mm	
Recess depth	57 mm	
Flange	22 mm	
Minimum diameter	400 mm	
Maximum diameter	1500 mm	

Our louvres come in a variety of dimensions, all of which can be used across most applications. When using large sizes in high-stress environments, such as at great heights, it is advisable to additionally verify the stability of the louvres and their mounting.

Available options

- **Custom flange:** Without flange
- **Thermally insulated:** Sandwich panel on back, with or without opening for air duct connection
- **Finish:** Anodised: layer thickness 25 microns / other colours / other textures (E1-E10)
Powder coating: pre-treatment in accordance with Seaside OX (pre-anodisation) / non-standard powders
- **Other mesh types:** Mesh sizes 2.3 mm x 2.3 mm, 6 mm x 6 mm, 10 mm x 10 mm or 20 mm x 20 mm / Stainless steel grade AISI304 or AISI316 / No mesh

421RC2

Aluminium burglar-resistant built-in louvre, Class RC2

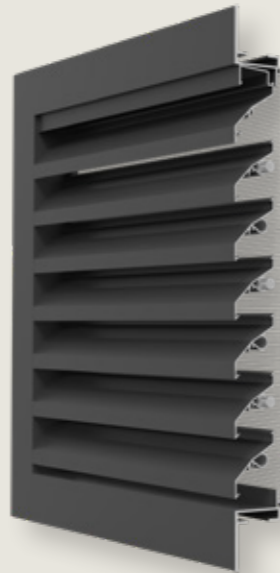

Material properties		Standard version	
Material	Aluminium, alloy EN AW-6063 T66		
Standard mesh type	Stainless steel 304 - 2.3 x 2.3 mm		
Surface treatment	Anodisation (20 microns), chemically etched F1-E6 natural colour	Polyester powder coating (60-80 micron) Seaside quality A & Standard powders	
Wall bracket type	no. 1427 (included)		
Dimensions			
Blade pitch	50 mm		
Recess depth	46 mm		
Flange	40 mm		
Minimum dimensions (W x H)	250 x 250 mm		
Maximum width	4000 mm		
Maximum height	4000 mm		
Width and height cannot both exceed 2000 mm			
Maximum louvre surface area	5 m ²		

Our louvres come in a variety of dimensions, all of which can be used across most applications. When using large sizes in high-stress environments, such as at great heights, it is advisable to additionally verify the stability of the louvres and their mounting.

Performance		
Airflow rate		
Physical free area		46 %
Visual free area		70%
Air supply	Resistance factor K	12.9
	Flow coefficient C	0.278
	Airflow rating	3
Air extraction	Resistance factor K	12.2
	Flow coefficient C	0.286
	Airflow rating	3
IP rating		
With mesh and water channel		IP23D (20 cm)*
Without water channel		IP2XD (10 cm)*

*Min. distance to electrical installation

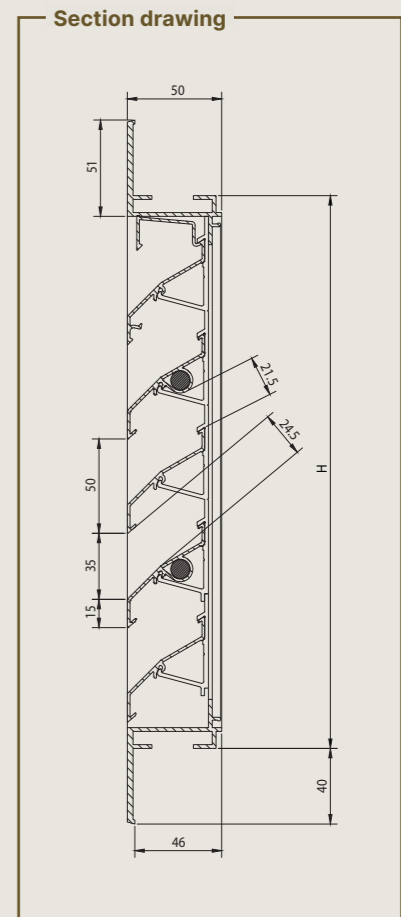

OUTSIDE
BUILT-IN

Available options

- **Custom flange:** Full surround or partial, with or without shortened flange
- **Thermally insulated:** Sandwich panel on back, with or without opening for air duct connection
- **Finish:** Anodised: layer thickness 25 microns / other colours / other textures (E1-E10)
Powder coating: pre-treatment in accordance with Seaside OX (pre-anodisation) / non-standard powders
- **Closable:** With sliding vent
- **Operation:** Slider / Rotary knob / Cord / Rod / Linear actuator (230V or 24V)
- **Other mesh types:** Mesh sizes 2.3 mm x 2.3 mm, 6 mm x 6 mm, 10 mm x 10 mm or 20 mm x 20 mm / Stainless steel grade AISI304 or AISI316 / No mesh
- **Water channel / Removable mesh / Filter / Drainage blade**

421RC3

Aluminium burglar-resistant built-in louvre, Class RC3



Material properties		Standard version	
Material	Aluminium, alloy EN AW-6063 T66		
Standard mesh type	Stainless steel 304 - 2.3 × 2.3 mm		
Surface treatment	Anodisation (20 microns), chemically etched F1-E6 natural colour	Polyester powder coating (60-80 micron) Seaside quality A & Standard powders	
Wall bracket type	no. 1427 (included)		
Dimensions			
Blade pitch	50 mm		
Recess depth	46 mm		
Flange	40 mm		
Minimum dimensions (W x H)	300 × 300 mm		
Maximum width	2900 mm		
Maximum height	4000 mm		
Width and height cannot both exceed 2000 mm			
Maximum louvre surface area	3.3 m ²		

Our louvres come in a variety of dimensions, all of which can be used across most applications. When using large sizes in high-stress environments, such as at great heights, it is advisable to additionally verify the stability of the louvres and their mounting.

Performance		
Airflow rate		
Physical free area		46 %
Visual free area		70%
Air supply	Resistance factor K	12.9
	Flow coefficient C	0.278
	Airflow rating	3
Air extraction	Resistance factor K	12.2
	Flow coefficient C	0.286
	Airflow rating	3
IP rating		
With mesh and water channel		IP23D (20 cm)*
Without water channel		IP2XD (10 cm)*

*Min. distance to electrical installation

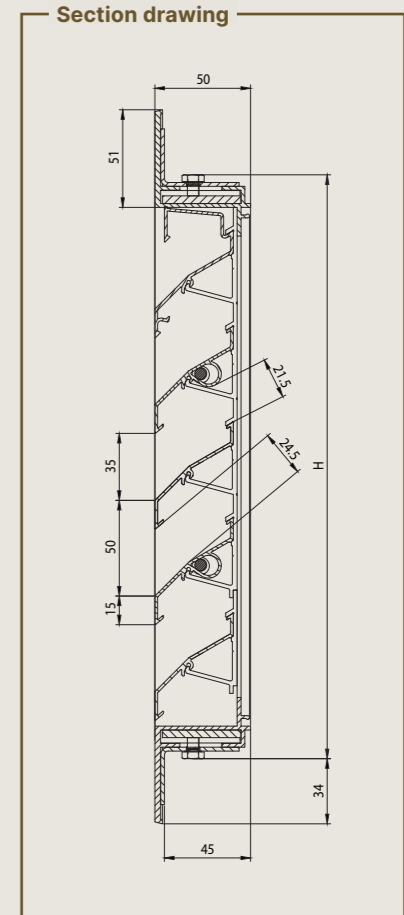

OUTSIDE
BUILT-IN

Available options

- **Thermally insulated:** Sandwich panel on back, with or without opening for air duct connection
- **Finish:** Anodised: layer thickness 25 microns / other colours / other textures (E1-E10)
Powder coating: pre-treatment in accordance with Seaside OX (pre-anodisation) / non-standard powders
- **Closable:** With sliding vent
- **Operation:** Slider / Rotary knob / Cord / Rod / Linear actuator (230V or 24V)
- **Other mesh types:** Mesh sizes 2.3 mm x 2.3 mm, 6 mm x 6 mm, 10 mm x 10 mm or 20 mm x 20 mm / Stainless steel grade AISI304 or AISI316 / No mesh
- **Water channel / Removable mesh / Filter / Drainage blade**

427

Aluminium adjustable built-in louvre

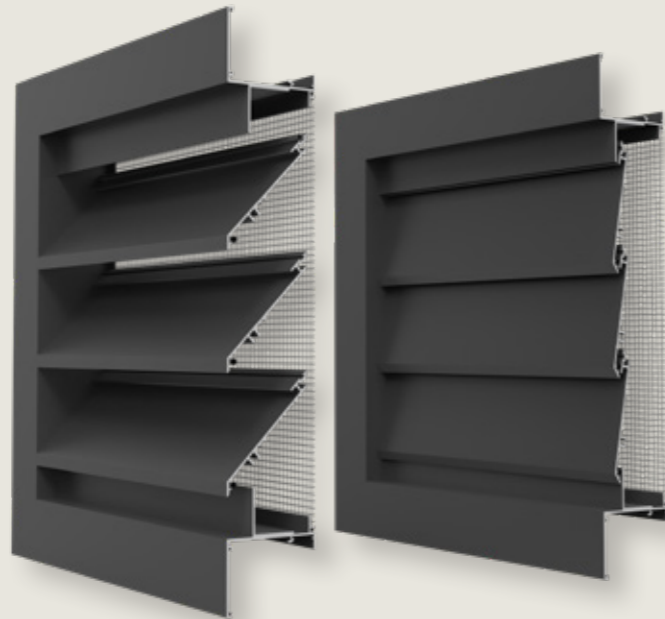

Performance		
Airflow rate		
Physical free area		53%
Visual free area		88%
Air supply	Resistance factor K	11.4
	Flow coefficient C	0.296
	Airflow rating	3
Air extraction	Resistance factor K	11.7
	Flow coefficient C	0.293
	Airflow rating	3

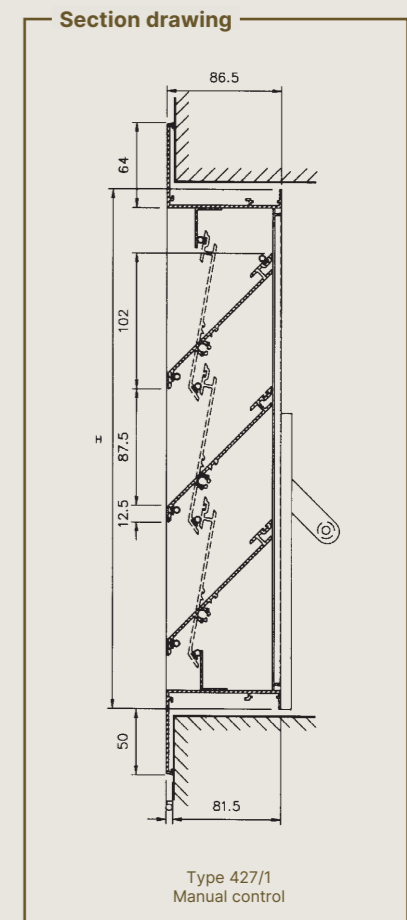

OUTSIDE
BUILT-IN

Material properties	Standard version	
Material	Aluminium, alloy EN AW-6063 T66	
Standard mesh type	Stainless steel 304 - 6 x 6 mm	
Surface treatment	Anodisation (20 microns), chemically etched F1-E6 natural colour	Polyester powder coating (60-80 micron) Seaside quality A & Standard powders
Wall bracket type	no. 429 (included)	
Dimensions		
Blade pitch	100 mm	
Recess depth	82 mm	
Flange	50 mm	
Minimum dimensions (W x H)	300 x 290 mm – depending on the control type	
Maximum width	1300 mm	
Maximum height	1990 mm	
Maximum louvre surface area	5 m ²	
Preferred height	290 mm + (n x 100)	

Our louvres come in a variety of dimensions, all of which can be used across most applications. When using large sizes in high-stress environments, such as at great heights, it is advisable to additionally verify the stability of the louvres and their mounting.

Available options

- **Counterframe:** Narrow counterframe for panel thicknesses from 77 mm to 101 mm
Deep counterframe for panel thicknesses from 102 mm to 128 mm
- **Mounting method:** Screw holes in flange frame
- **Custom flange:** Full surround or partial, with or without shortened flange
- **Closable**
- **Control:** 427/1: Manual / 427/2: Cable / 427/3: Ultraflex / 427/4: 230V or 24V linear actuator / 427/5: Pneumatic / 427/6: 230V or 24V fire damper actuator
- **Finish:** Anodised: layer thickness 25 microns / other colours / other textures (E1-E10)
Powder coating: pre-treatment in accordance with Seaside OX (pre-anodisation) / non-standard powders
- **Other mesh types:** Mesh sizes 2.3 mm x 2.3 mm, 6 mm x 6 mm, 10 mm x 10 mm or 20 mm x 20 mm / Stainless steel grade AISI304 or AISI316 / No mesh
- **Drainage blade**

434RD - 434RE - 435R

434RD: Compact round aluminium built-in louvre for air extraction (without mesh)

434RE: Compact round aluminium built-in louvre for air supply (with mesh)

435R: Compact round aluminium built-in louvre



434R



435R

Material properties	434RD	434RE	435R
Material	Aluminium		
Standard mesh type	-	Insect mesh	
Dimensions			
Recess depth	17 mm	51 mm	
Flange	12 mm	14 mm	

Stock models											
Type	Diameter	Renson Standard White	RAL 8019	RAL 7019	STR 7016	STR 9005	RAL 9006	Opening (cm ²)	Flow rate at 2 Pa (m ³ /h)	Flow rate at 10 Pa (m ³ /h)	Flow rate at 20 Pa (m ³ /h)
434RD	ø 100	13456	10549	-	10548	17458	10547	47.76	13	29.1	41.1
	ø 125	10551	13459	-	10550	13460	10122	73.55	25.2	56.3	79.7
434RE	ø 100	13457	10120	13458	10119	10121	10118	47.76	13	29.1	41.1
	ø 125	17459	10552	10553	10123	13462	13461	73.55	25.2	56.3	79.7
	ø 150	10124	13463	-	17460	13464	10554	106.84	36	80.5	113.8
	ø 160	10125	10126	-	-	10127	13465	121.66	44.6	99.7	141
	ø 200	10555	9800	-	-	9801	13466	197.6	94.7	211.8	299.5
435R	ø 80	17470	9803	-	17461	10561	10133	27	8.3	18.6	26.2
	ø 100	10134	10560	-	10128	10563	17471	51	15.2	34	48.1
	ø 120	17462	10130	-	17464	17463	9802	75	23.6	52.8	74.6
	ø 150	17466	10557	-	17467	10138	10556	119	35.2	78.7	111.3
	ø 190	10559	10132	-	9804	17469	10558	204	53.1	118.7	167.9
	ø 250	10141	10142	-	17472	10566	10140	250	339	165.5	234

434R section drawing

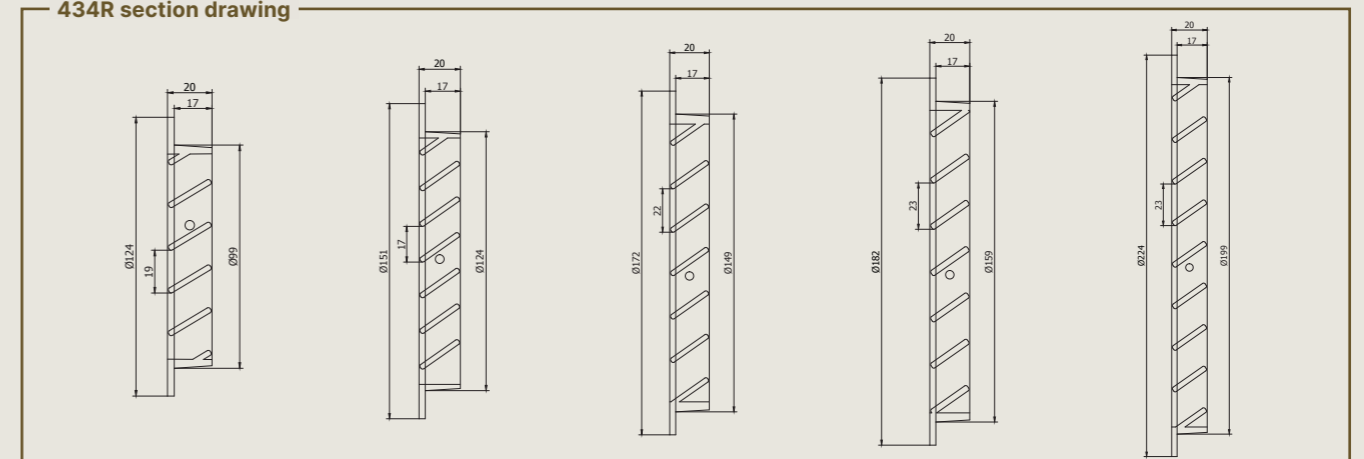

435R section drawing

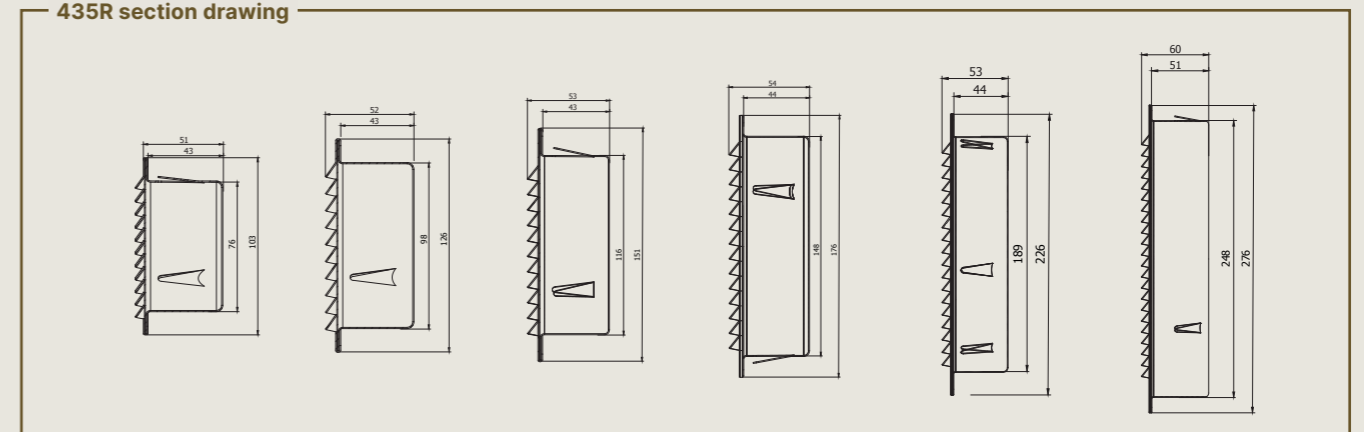

Available options - 435

- **Finish** Other colours available upon request

445/86

Aluminium noise-reducing built-in louvre, Rw 6dB

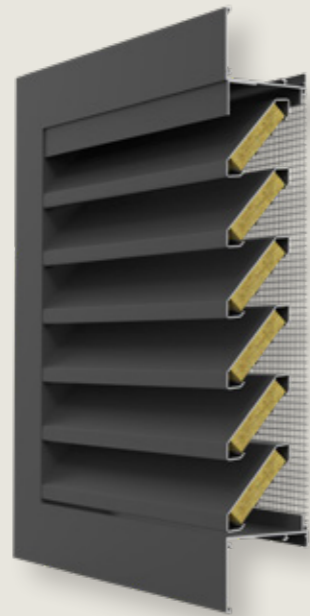

Material properties		Standard version	
Material	Aluminium–Mineral wool		
Standard mesh type	Stainless steel 304 - 6 × 6 mm		
Surface treatment	Anodisation (20 microns), chemically etched F1-E6 natural colour	Polyester powder coating (60–80 micron) Seaside quality A & Standard powders	
Wall bracket type	no. 429 (included)		
Dimensions			
Blade pitch	60 mm		
Recess depth	82 mm		
Flange	50 mm		
Minimum dimensions (W x H)	227 × 227 mm		
Maximum width	4000 mm		
Maximum height	4000 mm		
Width and height cannot both exceed 2000 mm			
Maximum louvre surface area	4.2 m ²		
Preferred height	227 mm + (n x 60)		

Our louvres come in a variety of dimensions, all of which can be used across most applications. When using large sizes in high-stress environments, such as at great heights, it is advisable to additionally verify the stability of the louvres and their mounting.

Performance								
Airflow rate								
Physical free area		34%						
Visual free area		75%						
Air supply	Resistance factor K	10.7						
	Flow coefficient C	0.306						
	Airflow rating	2						
Air extraction	Resistance factor K	10.0						
	Flow coefficient C	0.316						
	Airflow rating	2						
Water resistance %								
at (m/s)	0.0	0.5	1.0	1.5	2.0	2.5	3.0	3.5
With 2 x 2 mesh and water channel	B	B	C	D	D	D	D	D
	98.0	95.2	89.9	76.7	47.6	20.2	15.4	8.3
Without water channel	C	D	D	D	D	D	D	D
	83.3	73.5	63.2	50.6	37.6	28.5	23.5	20.2
Noise reduction dB								
R _w (C;C _r)	6 (-1; -2)							
f in Hz	R in dB							
63	7.3							
125	4.1							
250	1.3							
500	1.7							
1000	4.6							
2000	9.2							
4000	10.7							

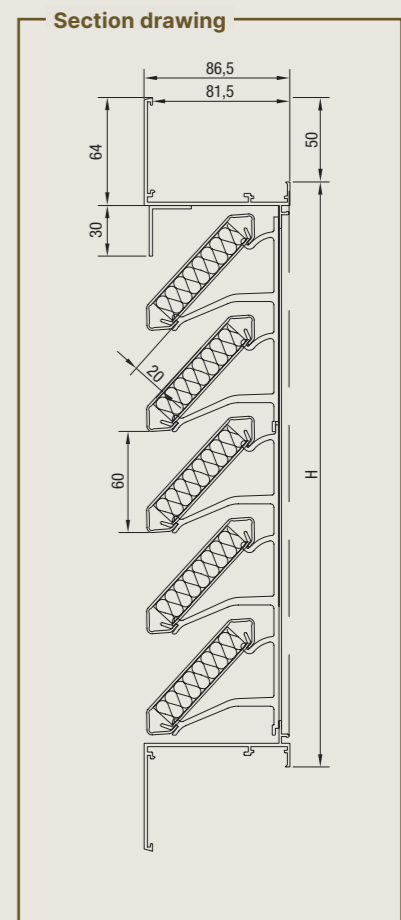

OUTSIDE
BUILT-IN

Available options

- **Counterframe:** Narrow counterframe for panel thicknesses from 77 mm to 101 mm
Deep counterframe for panel thicknesses from 102 mm to 128 mm
- **Mounting method:** Screw holes in flange frame
- **Custom flange:** Full surround or partial, with or without shortened flange
- **Closable:** With sliding vent
- **Operation:** Slider / Rotary knob / Cord / Rod / Linear actuator (230V or 24V)
- **Thermally insulated:** Sandwich panel on back, with or without opening for air duct connection
- **Finish:** Anodised: layer thickness 25 microns / other colours / other textures (E1-E10)
Powder coating: pre-treatment in accordance with Seaside OX (pre-anodisation) / non-standard powders
- **Other mesh types:** Mesh sizes 2.3 mm x 2.3 mm, 6 mm x 6 mm, 10 mm x 10 mm or 20 mm x 20 mm / Stainless steel grade AISI304 or AISI316 / No mesh
- **Special shapes / Water channel / Removable mesh / Filter / Drainage blade / Joining**

448D

Aluminium built-in louvre to match noise-reducing 448 louvres



Performance									
Airflow rate									
Physical free area		33%							
Visual free area		65%							
Air supply	Resistance factor K		51.8						
	Flow coefficient C		0.139						
	Airflow rating		4						
Air extraction	Resistance factor K		51.8						
	Flow coefficient C		0.139						
	Airflow rating		4						
Water resistance %									
at (m/s)		0.0	0.5	1.0	1.5	2.0	2.5	3.0	3.5
Without water channel	A		B	B	C	D	D	D	D
	99,0		98,3	97,1	91,4	68,4	46,4	32,8	17,8

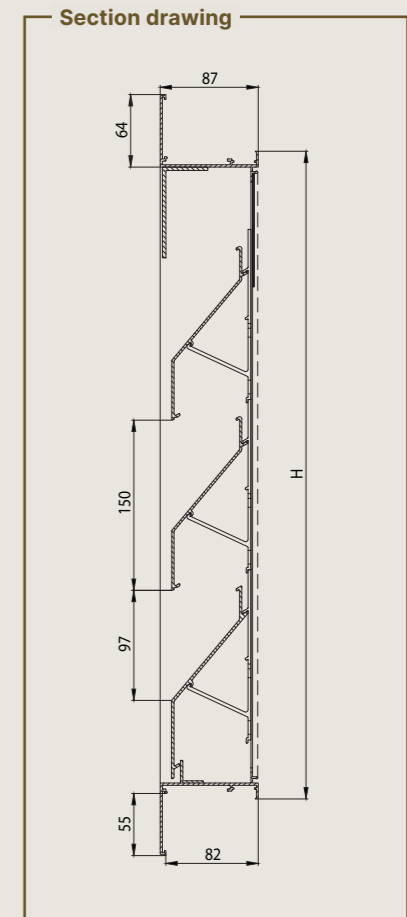

OUTSIDE
BUILT-IN

Material properties		Standard version	
Material	Aluminium, alloy EN AW-6063 T66		
Standard mesh type	Stainless steel 304 - 6 x 6 mm		
Surface treatment	Anodisation (20 microns), chemically etched F1-E6 natural colour	Polyester powder coating (60-80 micron) Seaside quality A & Standard powders	
Wall bracket type	no. 429 (included)		
Dimensions			
Blade pitch	150 mm		
Recess depth	82 mm		
Flange	50 mm		
Minimum dimensions (W x H)	227 x 421 mm		
Maximum width	4000 mm		
Maximum height	4000 mm		
Width and height cannot both exceed 2000 mm			
Maximum louvre surface area	8.8 m ²		

Our louvres come in a variety of dimensions, all of which can be used across most applications. When using large sizes in high-stress environments, such as at great heights, it is advisable to additionally verify the stability of the louvres and their mounting.

Available options

- **Counterframe:** Narrow counterframe for panel thicknesses from 77 mm to 101 mm
Deep counterframe for panel thicknesses from 102 mm to 128 mm
- **Mounting method:** Screw holes in flange frame
- **Custom flange:** Full surround or partial, with or without shortened flange
- **Closable:** With sliding vent
- **Operation:** Slider / Rotary knob / Cord / Rod / Linear actuator (230V or 24V)
- **Thermally insulated:** Sandwich panel on back, with or without opening for air duct connection
- **Finish:** Anodised: layer thickness 25 microns / other colours / other textures (E1-E10)
Powder coating: pre-treatment in accordance with Seaside OX (pre-anodisation) / non-standard powders
- **Other mesh types:** Mesh sizes 2.3 mm x 2.3 mm, 6 mm x 6 mm, 10 mm x 10 mm or 20 mm x 20 mm / Stainless steel grade AISI304 or AISI316 / No mesh
- **Special shapes / Water channel / Removable mesh / Filter / Drainage blade / Joining**

448/150

Aluminium noise-reducing built-in louvre, Rw 11dB

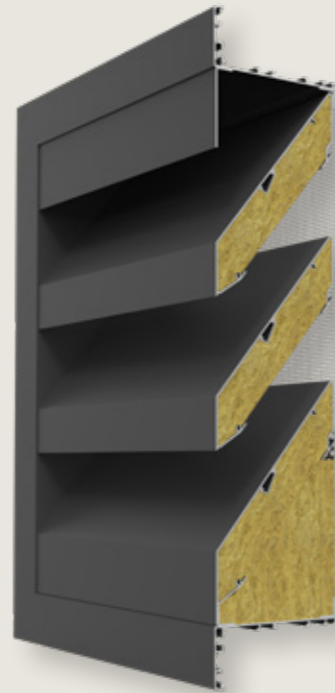

Material properties		Standard version	
Material	Aluminium - Mineral wool		
Standard mesh type	Stainless steel 304 - 6 x 6 mm		
Surface treatment	Anodisation (20 microns), chemically etched F1-E6 natural colour	Polyester powder coating (60-80 micron) Seaside quality A & Standard powders	
Wall bracket type	no. 1428 (included)		
Dimensions			
Blade pitch	150 mm		
Recess depth	143 mm		
Flange	55 mm		
Minimum dimensions (W x H)	200 x 410 mm		
Maximum width	2000 mm		
Maximum height	4000 mm		
Maximum louvre surface area	2.9 m ²		
Preferred height	410 mm + (n x 150)		

Our louvres come in a variety of dimensions, all of which can be used across most applications. When using large sizes in high-stress environments, such as at great heights, it is advisable to additionally verify the stability of the louvres and their mounting.

Performance								
Airflow rate								
Physical free area		34%						
Visual free area		64%						
Air supply	Resistance factor K	16						
	Flow coefficient C	0.250						
	Airflow rating	3						
Air extraction	Resistance factor K	21.2						
	Flow coefficient C	0.217						
	Airflow rating	3						
Water resistance %								
at (m/s)	0.0	0.5	1.0	1.5	2.0	2.5	3.0	3.5
Without water channel	B	C	C	D	D	D	D	D
	96.7	91.3	84.6	72.4	53.0	42.4	37.0	17.9
Noise reduction dB								
R _w (C; C _{tr})	11 (0; -2)							
f in Hz	R in dB							
63	8.8							
125	4.4							
250	6.1							
500	6.5							
1000	12.3							
2000	13.7							
4000	12.2							

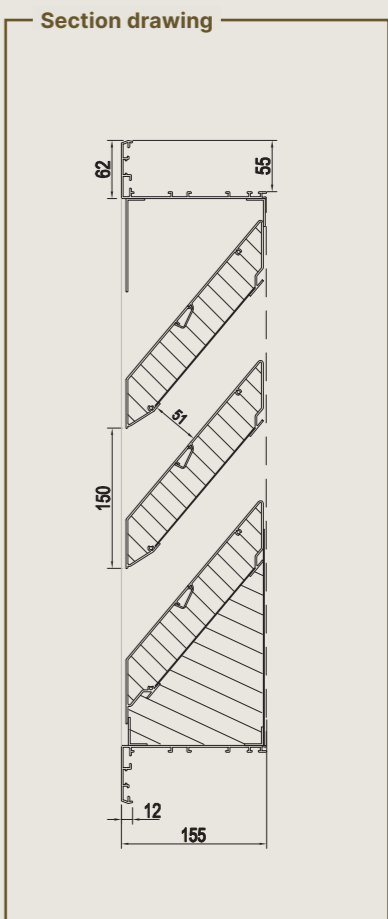

OUTSIDE
BUILT-IN

Available options

- **Mounting method:** Screw holes in flange frame
- **Custom flange:** Full surround or partial, with or without shortened flange
- **Closable:** With sliding vent
- **Operation:** Slider / Rotary knob / Cord / Rod / Linear actuator (230V or 24V)
- **Thermally insulated:** Sandwich panel on back, with or without opening for air duct connection
- **Finish:** Anodised: layer thickness 25 microns / other colours / other textures (E1-E10)
Powder coating: pre-treatment in accordance with Seaside OX (pre-anodisation) / non-standard powders
- **Other mesh types:** Mesh sizes 2.3 mm x 2.3 mm, 6 mm x 6 mm, 10 mm x 10 mm or 20 mm x 20 mm / Stainless steel grade AISI304 or AISI316 / No mesh
- **Water channel / Removable mesh / Filter / Drainage blade / Joining**

448/225

Aluminium noise-reducing built-in louvre, Rw 16 dB

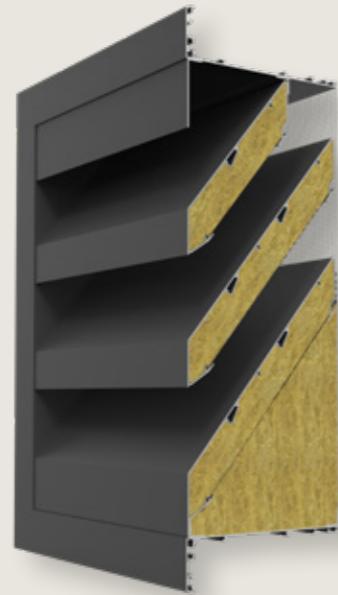

Material properties		Standard version	
Material	Aluminium - Mineral wool		
Standard mesh type	Stainless steel 304 - 6 x 6 mm		
Surface treatment	Anodisation (20 microns), chemically etched F1-E6 natural colour	Polyester powder coating (60-80 micron) Seaside quality A & Standard powders	
Wall bracket type	no. 1428 (included)		
Dimensions			
Blade pitch	150 mm		
Recess depth	218 mm		
Flange	55 mm		
Minimum dimensions (W x H)	200 x 410 mm		
Maximum width	2000 mm		
Maximum height	4000 mm		
Maximum louvre surface area	1.9 m ²		
Preferred height	410 mm + (n x 150)		

Our louvres come in a variety of dimensions, all of which can be used across most applications. When using large sizes in high-stress environments, such as at great heights, it is advisable to additionally verify the stability of the louvres and their mounting.

Performance								
Airflow rate								
Physical free area		34%						
Visual free area		64%						
Air supply	Resistance factor K	20.3						
	Flow coefficient C	0.222						
	Airflow rating	3						
Air extraction	Resistance factor K	23.1						
	Flow coefficient C	0.208						
	Airflow rating	3						
Water resistance %								
at (m/s)	0.0	0.5	1.0	1.5	2.0	2.5	3.0	3.5
Without water channel	C	C	D	D	D	D	D	D
	94.8	86.2	78.8	69.1	56.7	37.0	17.6	14.5
Noise reduction dB								
R _w (C _i ;C _e)	16 (-1;-4)							
f in Hz	R in dB							
63	9.8							
125	7.2							
250	5.8							
500	9.8							
1000	17.5							
2000	21.6							
4000	16.9							

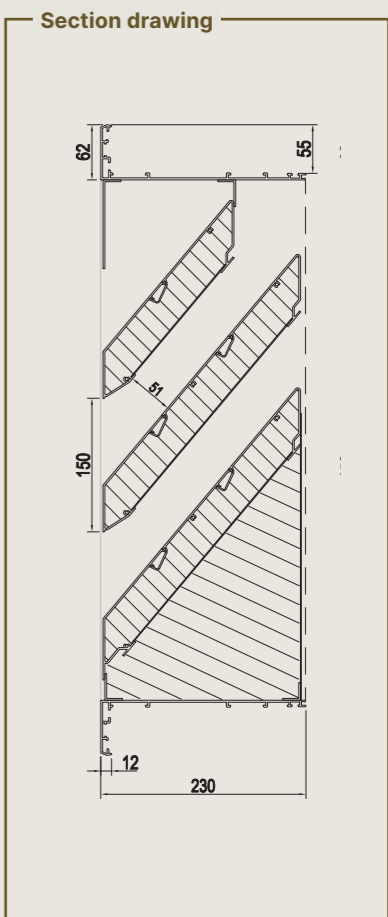

OUTSIDE
BUILT-IN

Available options

- **Mounting method:** Screw holes in flange frame
- **Custom flange:** Full surround or partial, with or without shortened flange
- **Closable:** With sliding vent
- **Operation:** Slider / Rotary knob / Cord / Rod / Linear actuator (230V or 24V)
- **Thermally insulated:** Sandwich panel on back, with or without opening for air duct connection
- **Finish:** Anodised: layer thickness 25 microns / other colours / other textures (E1-E10)
Powder coating: pre-treatment in accordance with Seaside OX (pre-anodisation) / non-standard powders
- **Other mesh types:** Mesh sizes 2.3 mm x 2.3 mm, 6 mm x 6 mm, 10 mm x 10 mm or 20 mm x 20 mm / Stainless steel grade AISI304 or AISI316 / No mesh
- **Water channel / Removable mesh / Filter / Drainage blade / Joining**

448/300

Aluminium noise-reducing built-in louvre, Rw 18 dB



Material properties		Standard version	
Material	Aluminium - Mineral wool		
Standard mesh type	Stainless steel 304 - 6 x 6 mm		
Surface treatment	Anodisation (20 microns), chemically etched F1-E6 natural colour	Polyester powder coating (60-80 micron) Seaside quality A & Standard powders	
Wall bracket type	no. 1428 (included)		
Dimensions			
Blade pitch	150 mm		
Recess depth	293 mm		
Flange	55 mm		
Minimum dimensions (W x H)	211 x 421 mm		
Maximum width	2000 mm		
Maximum height	4000 mm		
Maximum louvre surface area	1.5m ²		
Preferred height	421 mm + (n x 150)		

Our louvres come in a variety of dimensions, all of which can be used across most applications. When using large sizes in high-stress environments, such as at great heights, it is advisable to additionally verify the stability of the louvres and their mounting.

Performance								
Airflow rate								
Physical free area			34%					
Visual free area			64%					
Air supply	Resistance factor K		25.8					
	Flow coefficient C		0.197					
	Airflow rating		4					
Air extraction	Resistance factor K		27.1					
	Flow coefficient C		0.192					
	Airflow rating		4					
Water resistance %								
at (m/s)	0.0	0.5	1.0	1.5	2.0	2.5	3.0	3.5
Without water channel	C	C	D	D	D	D	D	D
	91.2	80.4	71.3	61.6	50.0	33.3	17.5	10.8
Noise reduction dB								
R _w (C;C _r)		18 (-1;-5)						
f in Hz		R in dB						
63		11.9						
125		5.6						
250		6.3						
500		11.9						
1000		22.3						
2000		25.6						
4000		22.8						

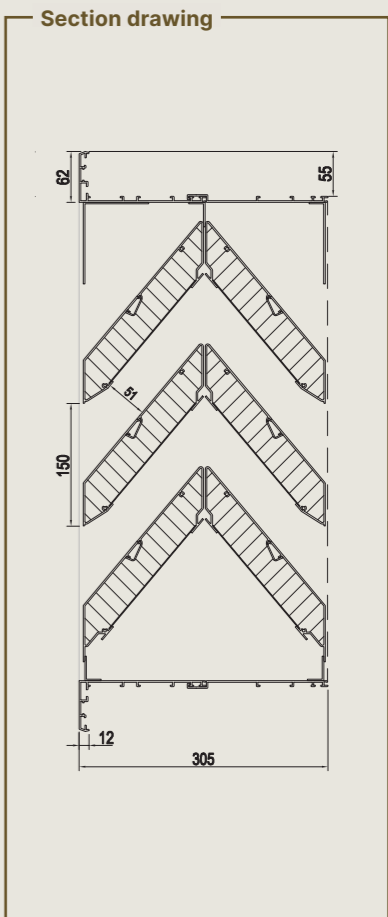

OUTSIDE
BUILT-IN

Available options

- **Mounting method:** Screw holes in flange frame
- **Custom flange:** Full surround or partial, with or without shortened flange
- **Closable:** With sliding vent
- **Operation:** Slider / Rotary knob / Cord / Rod / Linear actuator (230V or 24V)
- **Thermally insulated:** Sandwich panel on back, with or without opening for air duct connection
- **Finish:** Anodised: layer thickness 25 microns / other colours / other textures (E1-E10)
Powder coating: pre-treatment in accordance with Seaside OX (pre-anodisation) / non-standard powders
- **Other mesh types:** Mesh sizes 2.3 mm x 2.3 mm, 6 mm x 6 mm, 10 mm x 10 mm or 20 mm x 20 mm / Stainless steel grade AISI304 or AISI316 / No mesh
- **Removable mesh / Filter**

449D

Aluminium built-in louvre to match noise-reducing 449 louvres

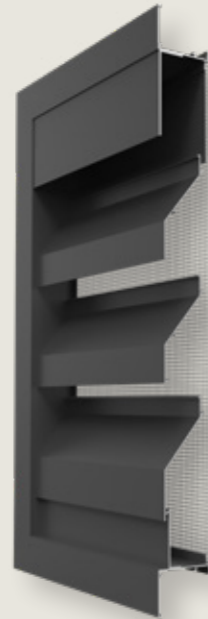

Performance								
Airflow rate								
Physical free area		32%						
Visual free area		69%						
Air supply	Resistance factor K		39.1					
	Flow coefficient C		0.160					
	Airflow rating		4					
Air extraction	Resistance factor K		37.2					
	Flow coefficient C		0.164					
	Airflow rating		4					
Water resistance %								
at (m/s)	0.0	0.5	1.0	1.5	2.0	2.5	3.0	3.5
Without water channel	B	B	C	C	D	D	D	D
	96,9	95,6	93,7	87,1	72,8	45,9	30,9	28,4

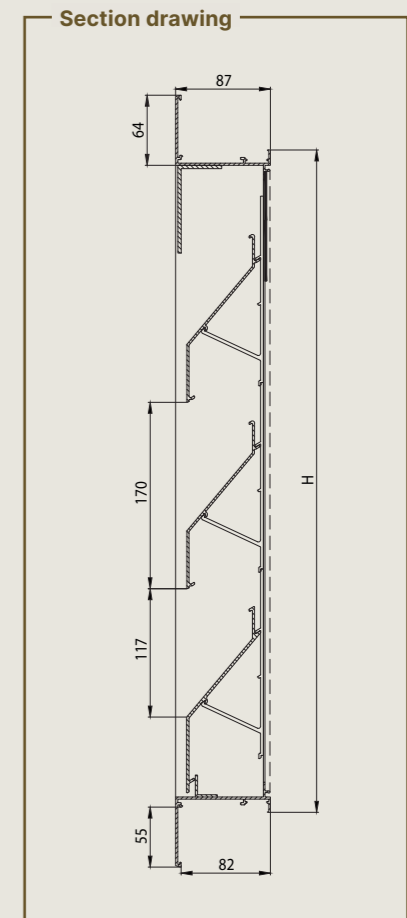

OUTSIDE
BUILT-IN

Material properties		Standard version	
Material	Aluminium, alloy EN AW-6063 T66		
Standard mesh type	Stainless steel 304 - 6 x 6 mm		
Surface treatment	Anodisation (20 microns), chemically etched F1-E6 natural colour	Polyester powder coating (60-80 micron) Seaside quality A & Standard powders	
Wall bracket type	no. 429 (included)		
Dimensions			
Blade pitch	170 mm		
Recess depth	82 mm		
Flange	50 mm		
Minimum dimensions (W x H)	227 x 434 mm		
Maximum width	4000 mm		
Maximum height	4000 mm		
Width and height cannot both exceed 2000 mm			
Maximum louvre surface area	9.9 m ²		

Our louvres come in a variety of dimensions, all of which can be used across most applications. When using large sizes in high-stress environments, such as at great heights, it is advisable to additionally verify the stability of the louvres and their mounting.

Available options

- **Counterframe:** Narrow counterframe for panel thicknesses from 77 mm to 101 mm
Deep counterframe for panel thicknesses from 102 mm to 128 mm
- **Mounting method:** Screw holes in flange frame
- **Custom flange:** Full surround or partial, with or without shortened flange
- **Closable:** With sliding vent
- **Operation:** Slider / Rotary knob / Cord / Rod / Linear actuator (230V or 24V)
- **Thermally insulated:** Sandwich panel on back, with or without opening for air duct connection
- **Finish:** Anodised: layer thickness 25 microns / other colours / other textures (E1-E10)
Powder coating: pre-treatment in accordance with Seaside OX (pre-anodisation) / non-standard powders
- **Other mesh types:** Mesh sizes 2.3 mm x 2.3 mm, 6 mm x 6 mm, 10 mm x 10 mm or 20 mm x 20 mm / Stainless steel grade AISI304 or AISI316 / No mesh
- **Special shapes / Water channel / Removable mesh / Filter / Drainage blade / Joining**

449/150

Aluminium noise-reducing built-in louvre, Rw 10 dB

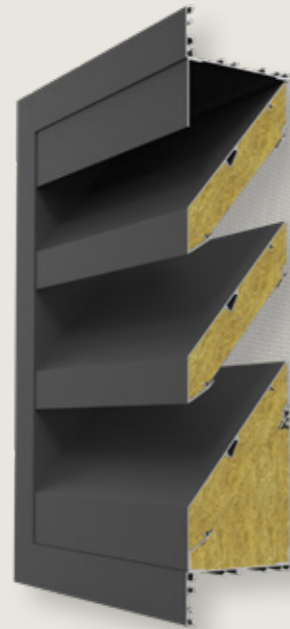

Material properties		Standard version	
Material	Aluminium - Mineral wool		
Standard mesh type	Stainless steel 304 - 6 x 6 mm		
Surface treatment	Anodisation (20 microns), chemically etched F1-E6 natural colour	Polyester powder coating (60-80 micron) Seaside quality A & Standard powders	
Wall bracket type	no. 1428 (included)		
Dimensions			
Blade pitch	170 mm		
Recess depth	143 mm		
Flange	55 mm		
Minimum dimensions (W x H)	200 x 430 mm		
Maximum width	2000 mm		
Maximum height	4000 mm		
Maximum louvre surface area	2.9 m ²		
Preferred height	430 mm + (n x 170)		

Our louvres come in a variety of dimensions, all of which can be used across most applications. When using large sizes in high-stress environments, such as at great heights, it is advisable to additionally verify the stability of the louvres and their mounting.

Performance								
Airflow rate								
Physical free area		37%						
Visual free area		69%						
Air supply	Resistance factor K	14.6						
	Flow coefficient C	0.262						
	Airflow rating	4						
Air extraction	Resistance factor K	19.1						
	Flow coefficient C	0.200						
	Airflow rating	4						
Water resistance %								
at (m/s)	0.0	0.5	1.0	1.5	2.0	2.5	3.0	3.5
Without water channel	C	D	D	D	D	D	D	D
	88.0	78.5	71.1	62.4	53.6	40.4	29.9	18.2
Noise reduction dB								
R _w (C; C _{tr})	10 (0 ; -1)							
f in Hz	R in dB							
63	6.8							
125	5.3							
250	5.6							
500	6.4							
1000	10.8							
2000	12.3							
4000	11.1							

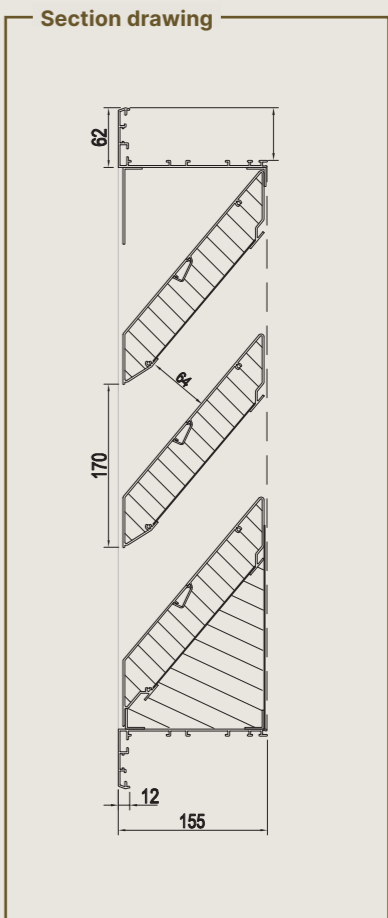

OUTSIDE
BUILT-IN

Available options

- **Mounting method:** Screw holes in flange frame
- **Custom flange:** Full surround or partial, with or without shortened flange
- **Closable:** With sliding vent
- **Operation:** Slider / Rotary knob / Cord / Rod / Linear actuator (230V or 24V)
- **Thermally insulated:** Sandwich panel on back, with or without opening for air duct connection
- **Finish:** Anodised: layer thickness 25 microns / other colours / other textures (E1-E10)
Powder coating: pre-treatment in accordance with Seaside OX (pre-anodisation) / non-standard powders
- **Other mesh types:** Mesh sizes 2.3 mm x 2.3 mm, 6 mm x 6 mm, 10 mm x 10 mm or 20 mm x 20 mm / Stainless steel grade AISI304 or AISI316 / No mesh
- **Water channel / Removable mesh / Filter / Drainage blade / Joining**

449/225

Aluminium noise-reducing built-in louvre, Rw 14 dB

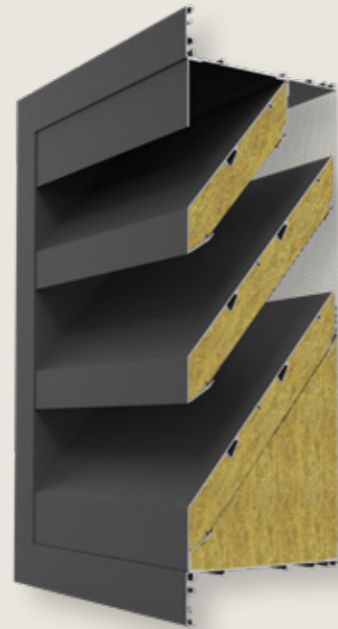

Material properties		Standard version	
Material	Aluminium - Mineral wool		
Standard mesh type	Stainless steel 304 - 6 x 6 mm		
Surface treatment	Anodisation (20 microns), chemically etched F1-E6 natural colour	Polyester powder coating (60-80 micron) Seaside quality A & Standard powders	
Wall bracket type	no. 1428 (included)		
Dimensions			
Blade pitch	170 mm		
Recess depth	218 mm		
Flange	55 mm		
Minimum dimensions (W x H)	200 x 430 mm		
Maximum width	2000 mm		
Maximum height	4000 mm		
Maximum louvre surface area	2.1 m ²		
Preferred height	430 mm + (n x 170)		

Our louvres come in a variety of dimensions, all of which can be used across most applications. When using large sizes in high-stress environments, such as at great heights, it is advisable to additionally verify the stability of the louvres and their mounting.

Performance								
Airflow rate								
Physical free area		37%						
Visual free area		69%						
Air supply	Resistance factor K	19.1						
	Flow coefficient C	0.229						
	Airflow rating	3						
Air extraction	Resistance factor K	21.4						
	Flow coefficient C	0.180						
	Airflow rating	4						
Water resistance %								
at (m/s)	0.0	0.5	1.0	1.5	2.0	2.5	3.0	3.5
Without water channel	C	C	D	D	D	D	D	D
	93.2	84.9	78.6	71.0	61.7	50.6	26.5	19.8
Noise reduction dB								
R _w (C;C _{tr})	14 (-1;-3)							
f in Hz	R in dB							
63	10.0							
125	6.1							
250	5.6							
500	8.6							
1000	15.8							
2000	18.0							
4000	14.3							

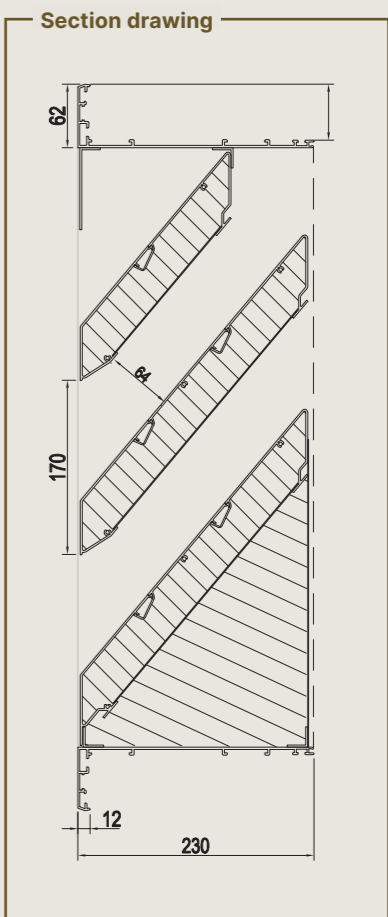

OUTSIDE
BUILT-IN

Available options

- **Mounting method:** Screw holes in flange frame
- **Custom flange:** Full surround or partial, with or without shortened flange
- **Closable:** With sliding vent
- **Operation:** Slider / Rotary knob / Cord / Rod / Linear actuator (230V or 24V)
- **Thermally insulated:** Sandwich panel on back, with or without opening for air duct connection
- **Finish:** Anodised: layer thickness 25 microns / other colours / other textures (E1-E10)
Powder coating: pre-treatment in accordance with Seaside OX (pre-anodisation) / non-standard powders
- **Other mesh types:** Mesh sizes 2.3 mm x 2.3 mm, 6 mm x 6 mm, 10 mm x 10 mm or 20 mm x 20 mm / Stainless steel grade AISI304 or AISI316 / No mesh
- **Water channel / Removable mesh / Filter / Drainage blade / Joining**

450

Aluminium rain-resistant built-in louvre with high free area, Class A2



Material properties		Standard version	
Material	Aluminium, alloy EN AW-6063 T66		
Standard mesh type	Stainless steel 304 - 2.3 x 2.3 mm		
Surface treatment	Anodisation (20 microns), chemically etched F1-E6 natural colour	Polyester powder coating (60-80 micron) Seaside quality A & Standard powders	
Wall bracket type	no. 1428 (included)		
Dimensions			
Blade pitch	50 mm		
Recess depth	159 mm		
Flange	52 mm		
Minimum dimensions (W x H)	200 x 230 mm		
Maximum width	4000 mm		
Maximum height	3980 mm		
Maximum louvre surface area	2.3 m ²		
Preferred height	230 mm + (n x 50)		

Our louvres come in a variety of dimensions, all of which can be used across most applications. When using large sizes in high-stress environments, such as at great heights, it is advisable to additionally verify the stability of the louvres and their mounting.

Performance								
Airflow rate								
Physical free area		57%						
Visual free area		70%						
Air supply	Resistance factor K	10.5						
	Flow coefficient C	0.309						
	Airflow rating	2						
Air extraction	Resistance factor K	16.5						
	Flow coefficient C	0.246						
	Airflow rating	3						
IP rating								
With mesh and water channel		IP44						
Without water channel		IP2XD						
Water resistance %								
at (m/s)	0.0	0.5	1.0	1.5	2.0	2.5	3.0	3.5
With 2 x 2 mesh and water channel	A	A	A	A	A	A	A	C
	100	100	100	100	99.9	99.9	99.2	92.2
Without water channel	A	A	A	A	A	A	B	C
	99.5	99.4	99.7	99.8	99.8	99.2	96.6	79.1

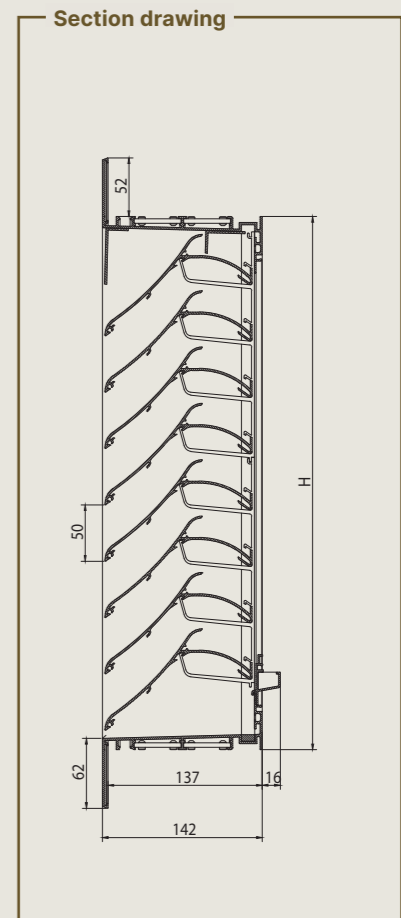

OUTSIDE
BUILT-IN

Available options

- **Mounting method:** Screw holes in flange frame
- **Custom flange:** Full surround or partial, with or without shortened flange
- **Thermally insulated:** Sandwich panel on back, with or without opening for air duct connection
- **Finish:** Anodised: layer thickness 25 microns / other colours / other textures (E1-E10)
Powder coating: pre-treatment in accordance with Seaside OX (pre-anodisation) / non-standard powders
- **Other mesh types:** Mesh sizes 2.3 mm x 2.3 mm, 6 mm x 6 mm, 10 mm x 10 mm or 20 mm x 20 mm / Stainless steel grade AISI304 or AISI316 / No mesh
- **Water channel / Removable mesh / Filter**

450V

Aluminium rain-resistant built-in louvre with high airflow, Class A2, vertical blade version



Class A

 3,5 m/s

Material properties		Standard version	
Material	Aluminium, alloy EN AW-6063 T66		
Standard mesh type	Stainless steel 304 - 2.3 × 2.3 mm		
Surface treatment	Anodisation (20 microns), chemically etched F1-E6 natural colour	Polyester powder coating (60-80 micron) Seaside quality A & Standard powders	
Wall bracket type	no. 1428 (included)		
Dimensions			
Blade pitch	50 mm		
Recess depth	159 mm		
Flange	52 mm		
Minimum dimensions (W x H)	230 × 200 mm		
Maximum width	2180 mm		
Maximum height	4000 mm		
Maximum louvre surface area	2.3 m ²		
Preferred width	230 mm + (n x 50)		

Our louvres come in a variety of dimensions, all of which can be used across most applications. When using large sizes in high-stress environments, such as at great heights, it is advisable to additionally verify the stability of the louvres and their mounting.

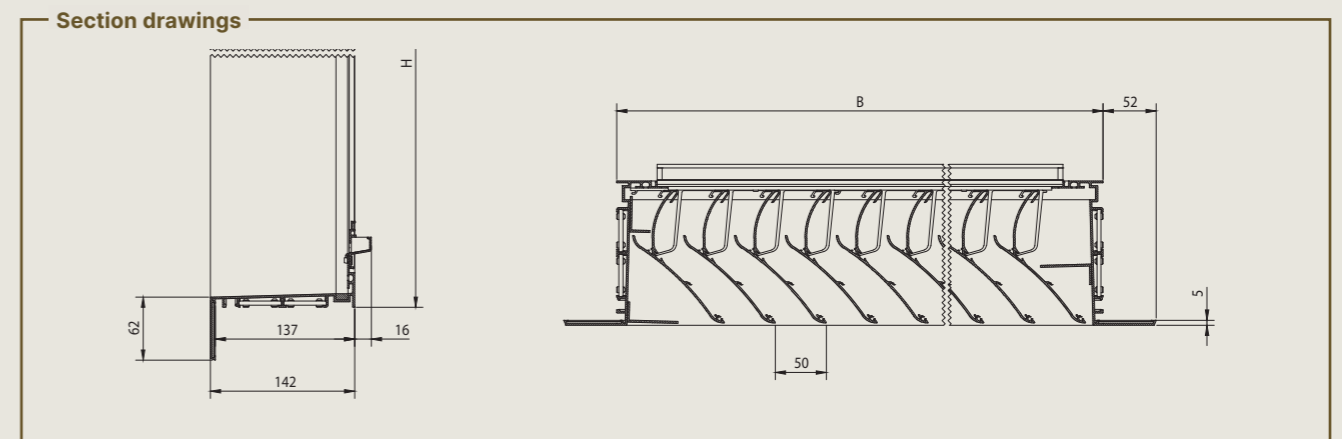
Performance								
Airflow rate								
Physical free area		57%						
Visual free area		70%						
Air supply	Resistance factor K	10.7						
	Flow coefficient C	0.306						
	Airflow rating	2						
Air extraction	Resistance factor K	16.5						
	Flow coefficient C	0.246						
	Airflow rating	3						
Water resistance %								
at (m/s)	0.0	0.5	1.0	1.5	2.0	2.5	3.0	3.5
With 2 x 2 mesh and water channel	A	A	A	A	A	A	A	A
	100	99.9	99.9	99.9	99.5	99.6	99.7	99.5



Available options

- **Mounting method:** Screw holes in flange frame
- **Custom flange:** Full surround or partial, with or without shortened flange
- **Thermally insulated:** Sandwich panel on back, with or without opening for air duct connection
- **Finish:**
 Anodised: layer thickness 25 microns / other colours / other textures (E1-E10)
 Powder coating: pre-treatment in accordance with Seaside OX (pre-anodisation) / non-standard powders
- **Other mesh types:** Mesh sizes 2.3 mm x 2.3 mm, 6 mm x 6 mm, 10 mm x 10 mm or 20 mm x 20 mm / Stainless steel grade AISI304 or AISI316 / No mesh
- **Water channel / Removable mesh / Filter**

452

Aluminium stick-proof louvre with 41% free area, Class A4, IP44

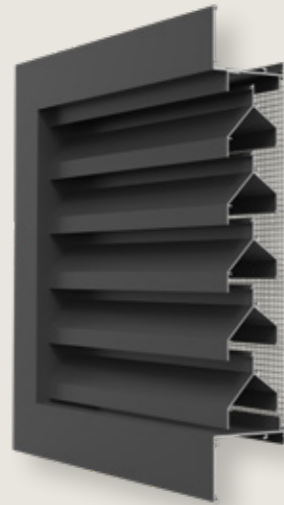

Material properties		Standard version	
Material	Aluminium, alloy EN AW-6063 T66		
Standard mesh type	Stainless steel 304 - 6 x 6 mm		
Surface treatment	Anodisation (20 microns), chemically etched F1-E6 natural colour	Polyester powder coating (60-80 micron) Seaside quality A & Standard powders	
Wall bracket type	no. 429 (included)		
Dimensions			
Blade pitch	66 mm		
Recess depth	82 mm		
Flange	50 mm		
Minimum dimensions (W x H)	310 x 300 mm		
Maximum width	4000 mm		
Maximum height	4000 mm		
Width and height cannot both exceed 2000 mm			
Maximum louvre surface area	5.1 m ²		

Our louvres come in a variety of dimensions, all of which can be used across most applications. When using large sizes in high-stress environments, such as at great heights, it is advisable to additionally verify the stability of the louvres and their mounting.

Performance								
Airflow rate								
Physical free area	41%							
Visual free area	70%							
Air supply	Resistance factor K	66.1						
	Flow coefficient C	0.123						
	Airflow rating	4						
Air extraction	Resistance factor K	79.7						
	Flow coefficient C	0.112						
	Airflow rating	4						
IP rating								
With mesh and water channel	IP44 (25 cm)*							
Without water channel	IP2XD							
Water resistance %								
at (m/s)	0.0	0.5	1.0	1.5	2.0	2.5	3.0	3.5
With 2 x 2 mesh and water channel	A	A	A	B	D	D	D	-
	100	99.9	99.6	95.0	56.9	28.3	11.6	-

*Min. distance to electrical installation

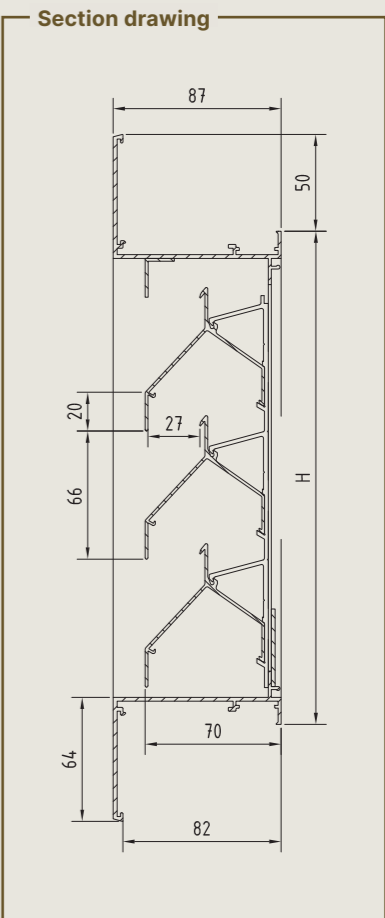

OUTSIDE
BUILT-IN

Available options

- Counterframe:** Narrow counterframe for panel thicknesses from 77 mm to 101 mm
Deep counterframe for panel thicknesses from 102 mm to 128 mm
- Mounting method:** Screw holes in flange frame
- Custom flange:** Full surround or partial, with or without shortened flange
- Closable:** With sliding vent
- Operation:** Slider / Rotary knob / Cord / Rod / Linear actuator (230V or 24V)
- Thermally insulated:** Sandwich panel on back, with or without opening for air duct connection
- Finish:** Anodised: layer thickness 25 microns / other colours / other textures (E1-E10)
Powder coating: pre-treatment in accordance with Seaside OX (pre-anodisation) / non-standard powders
- Other mesh types:** Mesh sizes 2.3 mm x 2.3 mm, 6 mm x 6 mm, 10 mm x 10 mm or 20 mm x 20 mm / Stainless steel grade AISI304 or AISI316 / No mesh
- Special shapes / Water channel / Removable mesh / Filter / Drainage blade / Joining**

457

Aluminium built-in louvre with 52% free area, Class B3

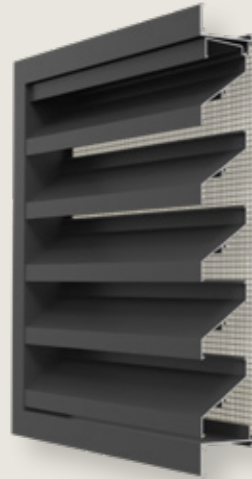

Performance								
Airflow rate								
Physical free area		52%						
Visual free area		73%						
Air supply	Resistance factor K	13.1						
	Flow coefficient C	0.276						
	Airflow rating	3						
Air extraction	Resistance factor K	14.2						
	Flow coefficient C	0.265						
	Airflow rating	3						
Water resistance %								
at (m/s)	0.0	0.5	1.0	1.5	2.0	2.5	3.0	3.5
With 2 x 2 mesh and water channel	B	B	C	C	D	D	D	D
	96.9	95.2	93.7	89.2	79.9	66.5	48.5	36.0
Without water channel	C	C	C	C	D	D	D	D
	90.4	87.3	84.8	81.3	73.9	54.9	37.7	15.5

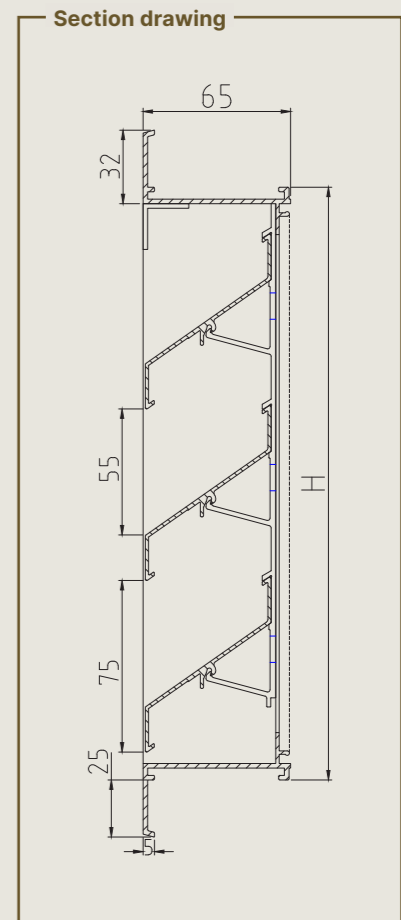

OUTSIDE
BUILT-IN

Material properties	Standard version	
Material	Aluminium, alloy EN AW-6063 T66	
Standard mesh type	Stainless steel 304 - 6 x 6 mm	
Surface treatment	Anodisation (20 microns), chemically etched F1-E6 natural colour	Polyester powder coating (60-80 micron) Seaside quality A & Standard powders
Wall bracket type	no. 429 (included)	
Dimensions		
Blade pitch	75 mm	
Recess depth	60 mm	
Flange	25 mm	
Minimum dimensions (W x H)	300 x 300 mm	
Maximum width	4000 mm	
Maximum height	4000 mm	
Width and height cannot both exceed 2000 mm		
Maximum louvre surface area	7.1 m ²	

Our louvres come in a variety of dimensions, all of which can be used across most applications. When using large sizes in high-stress environments, such as at great heights, it is advisable to additionally verify the stability of the louvres and their mounting.

Available options

- **Counterframe:** Narrow counterframe for panel thicknesses from 54 mm to 77 mm
Deep counterframe for panel thicknesses from 78 mm to 103 mm
- **Mounting method:** Screw holes in flange frame
- **Custom flange:** Full surround or partial, with or without shortened flange
- **Closable:** With sliding vent
- **Operation:** Slider / Rotary knob / Cord / Rod / Linear actuator (230V or 24V)
- **Thermally insulated:** Sandwich panel on back, with or without opening for air duct connection
- **Finish:** Anodised: layer thickness 25 microns / other colours / other textures (E1-E10)
Powder coating: pre-treatment in accordance with Seaside OX (pre-anodisation) / non-standard powders
- **Other mesh types:** Mesh sizes 2.3 mm x 2.3 mm, 6 mm x 6 mm, 10 mm x 10 mm or 20 mm x 20 mm / Stainless steel grade AISI304 or AISI316 / No mesh
- **Special shapes / Water channel / Removable mesh / Filter / Drainage blade / Joining**

458

Aluminium built-in louvre with 77% free area, compact version

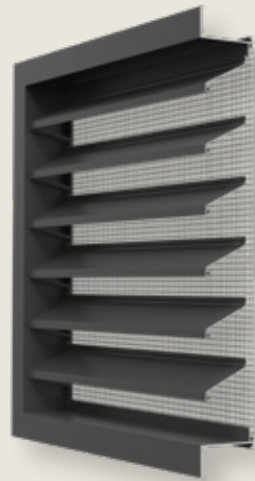

Performance		
Airflow rate		
Physical free area		77%
Visual free area		85%
Air supply	Resistance factor K	4.7
	Flow coefficient C	0.462
	Airflow rating	1
Air extraction	Resistance factor K	4.8
	Flow coefficient C	0.457
	Airflow rating	1

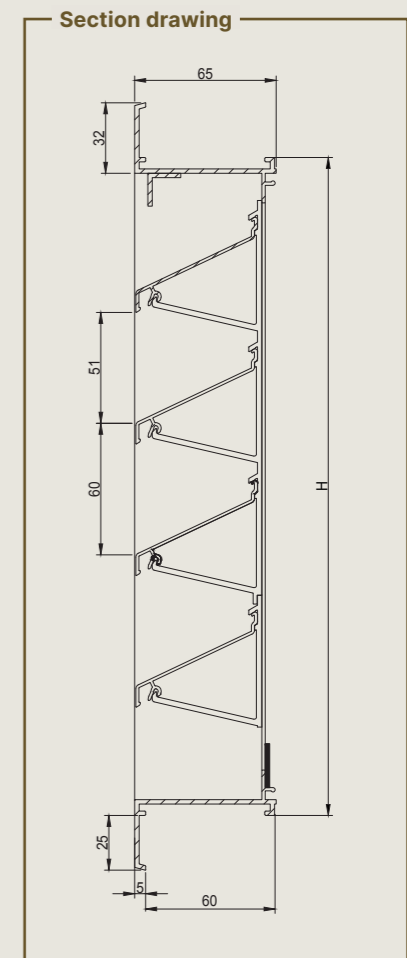

OUTSIDE
BUILT-IN

Material properties	Standard version	
Material	Aluminium, alloy EN AW-6063 T66	
Standard mesh type	Stainless steel 304 - 6 x 6 mm	
Surface treatment	Anodisation (20 microns), chemically etched F1-E6 natural colour	Polyester powder coating (60-80 micron) Seaside quality A & Standard powders
Wall bracket type	no. 429 (included)	
Dimensions		
Blade pitch	60 mm	
Recess depth	60 mm	
Flange	25 mm	
Minimum dimensions (W x H)	300 x 300 mm	
Maximum width	4000 mm	
Maximum height	4000 mm	
Width and height cannot both exceed 2000 mm		
Maximum louvre surface area	8 m ²	

Our louvres come in a variety of dimensions, all of which can be used across most applications. When using large sizes in high-stress environments, such as at great heights, it is advisable to additionally verify the stability of the louvres and their mounting.

Available options

- **Counterframe:** Narrow counterframe for panel thicknesses from 54 mm to 77 mm
Deep counterframe for panel thicknesses from 78 mm to 103 mm
- **Mounting method:** Screw holes in flange frame
- **Custom flange:** Full surround or partial, with or without shortened flange
- **Closable:** With sliding vent
- **Operation:** Slider / Rotary knob / Cord / Rod / Linear actuator (230V or 24V)
- **Thermally insulated:** Sandwich panel on back, with or without opening for air duct connection
- **Finish:** Anodised: layer thickness 25 microns / other colours / other textures (E1-E10)
Powder coating: pre-treatment in accordance with Seaside OX (pre-anodisation) / non-standard powders
- **Other mesh types:** Mesh sizes 2.3 mm x 2.3 mm, 6 mm x 6 mm, 10 mm x 10 mm or 20 mm x 20 mm / Stainless steel grade AISI304 or AISI316 / No mesh
- **Special shapes / Water channel / Removable mesh / Filter / Drainage blade / Joining**

468SA

Aluminium sand-trap built-in louvre

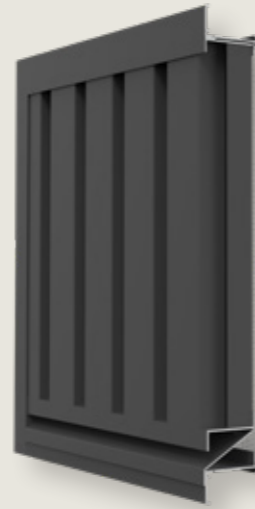

Material properties		Standard version	
Material	Aluminium, alloy EN AW-6063 T66		
Standard mesh type	Stainless steel 304 - 2.3 × 2.3 mm		
Surface treatment	Anodisation (20 microns), chemically etched F1-E6 natural colour	Polyester powder coating (60-80 micron) Seaside quality A & Standard powders	
Wall bracket type	no. 429 (included)		
Dimensions			
Blade pitch	85 mm		
Recess depth	60 mm		
Flange	25 mm		
Minimum dimensions (W x H)	185 × 185 mm		
Maximum width	2012 mm		
Maximum height	1200 mm		
Maximum louvre surface area	2.5 m ²		
Available widths	185 + (n × 42.5) mm		

Our louvres come in a variety of dimensions, all of which can be used across most applications. When using large sizes in high-stress environments, such as at great heights, it is advisable to additionally verify the stability of the louvres and their mounting.

Performance						
Airflow rate						
Physical free area		29%				
Visual free area		29%				
Air supply	Resistance factor K	115.6				
	Flow coefficient C	0.093				
	Airflow rating	4				
Air extraction	Resistance factor K	115.6				
	Flow coefficient C	0.093				
	Airflow rating	4				
IP rating						
With mesh and water channel		IP2XD				
Without water channel		IP2XD				
Sand-trap %						
at (m/s)		0,0	0,5	1,3	2,0	2,8
With 2 × 2 mesh		97	94	61	31	18

Section drawings

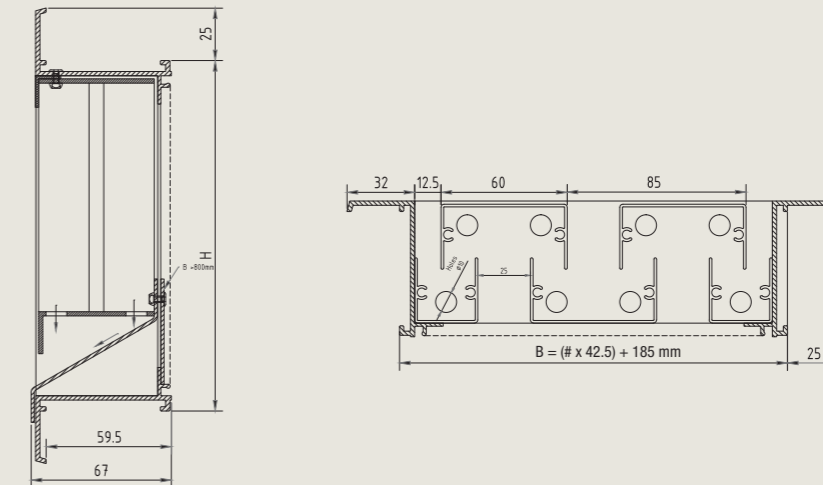

Available options

- **Counterframe:** Narrow counterframe for panel thicknesses from 54 mm to 77 mm
Deep counterframe for panel thicknesses from 78 mm to 103 mm
- **Mounting method:** Screw holes in flange frame
- **Custom flange:** Full surround or partial, with or without shortened flange
- **Thermally insulated:** Sandwich panel on back, with or without opening for air duct connection
- **Finish:** Anodised: layer thickness 25 microns / other colours / other textures (E1-E10)
Powder coating: pre-treatment in accordance with Seaside OX (pre-anodisation) / non-standard powders
- **Other mesh types:** Mesh sizes 2.3 mm x 2.3 mm, 6 mm x 6 mm, 10 mm x 10 mm or 20 mm x 20 mm / Stainless steel grade AISI304 or AISI316 / No mesh
- **Removable mesh / Filter**

480

Aluminium built-in louvre with 76% free area, deep version

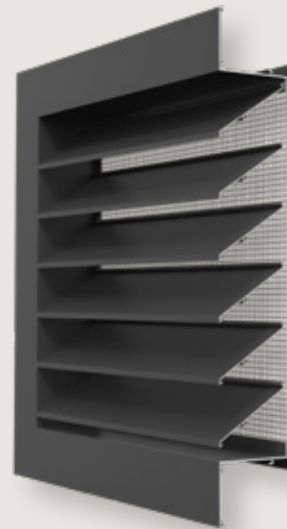

Performance								
Airflow rate								
Physical free area		76%						
Visual free area		90%						
Air supply	Resistance factor K	4.6						
	Flow coefficient C	0.466						
	Airflow rating	1						
Air extraction	Resistance factor K	5.2						
	Flow coefficient C	0.439						
	Airflow rating	1						
IP rating								
With mesh and water channel		IP2XD (18 cm)*						
Water resistance %								
at (m/s)	0.0	0.5	1.0	1.5	2.0	2.5	3.0	3.5
With 2 x 2 mesh and water channel	C	C	C	C	D	D	-	-
	90.1	87.3	84.2	80.1	73.4	62.0	-	-
Without water channel	D	D	D	D	D	D	D	D
	75.9	68.9	62.8	56.9	51.7	45.5	39.4	30.4

*Min. distance to electrical installation

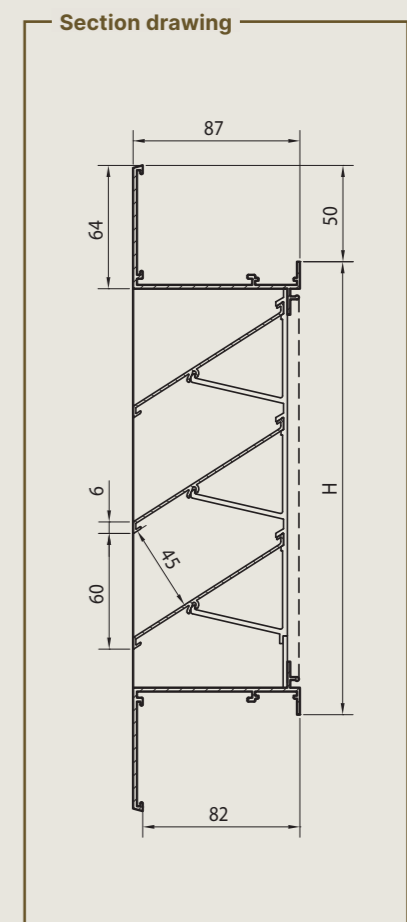

OUTSIDE
BUILT-IN

Material properties	Standard version	
Material	Aluminium, alloy EN AW-6063 T66	
Standard mesh type	Stainless steel 304 - 6 x 6 mm	
Surface treatment	Anodisation (20 microns), chemically etched F1-E6 natural colour	Polyester powder coating (60-80 micron) Seaside quality A & Standard powders
Wall bracket type	no. 429 (included)	
Dimensions		
Blade pitch	60 mm	
Recess depth	82 mm	
Flange	50 mm	
Minimum dimensions (W x H)	300 x 300 mm	
Maximum width	4000 mm	
Maximum height	4000 mm	
Width and height cannot both exceed 2000 mm		
Maximum louvre surface area	5.9 m ²	

Our louvres come in a variety of dimensions, all of which can be used across most applications. When using large sizes in high-stress environments, such as at great heights, it is advisable to additionally verify the stability of the louvres and their mounting.

Available options

- **Counterframe:** Narrow counterframe for panel thicknesses from 77 mm to 101 mm
Deep counterframe for panel thicknesses from 102 mm to 128 mm
- **Mounting method:** Screw holes in flange frame
- **Custom flange:** Full surround or partial, with or without shortened flange
- **Closable:** With sliding vent
- **Operation:** Slider / Rotary knob / Cord / Rod / Linear actuator (230V or 24V)
- **Thermally insulated:** Sandwich panel on back, with or without opening for air duct connection
- **Finish:** Anodised: layer thickness 25 microns / other colours / other textures (E1-E10)
Powder coating: pre-treatment in accordance with Seaside OX (pre-anodisation) / non-standard powders
- **Other mesh types:** Mesh sizes 2.3 mm x 2.3 mm, 6 mm x 6 mm, 10 mm x 10 mm or 20 mm x 20 mm / Stainless steel grade AISI304 or AISI316 / No mesh
- **Special shapes / Water channel / Removable mesh / Filter / Drainage blade / Joining**

481

Aluminium built-in louvre with 60% free area, Class B2

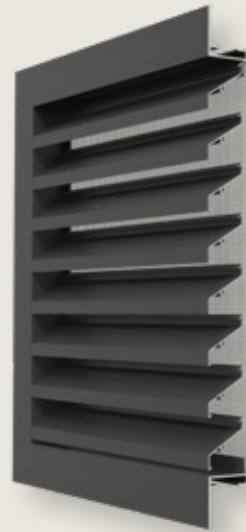

Performance								
Airflow rate								
Physical free area	60%							
Visual free area	70%							
Air supply	Resistance factor K	8.2						
	Flow coefficient C	0.349						
	Airflow rating	2						
Air extraction	Resistance factor K	9.8						
	Flow coefficient C	0.319						
	Airflow rating	2						
IP rating								
With mesh and water channel	IP2XD (10.5 cm)*							
Water resistance %								
at (m/s)	0.0	0.5	1.0	1.5	2.0	2.5	3.0	3.5
With 2 x 2 mesh and water channel	B	C	C	C	D	D	D	D
	96.0	94.3	92.2	88.2	76.9	57.3	42.4	33.0
Without water channel	C	C	C	D	D	D	D	D
	90.6	86.4	80.8	72.0	51.4	31.8	22.0	13.7

*Min. distance to electrical installation

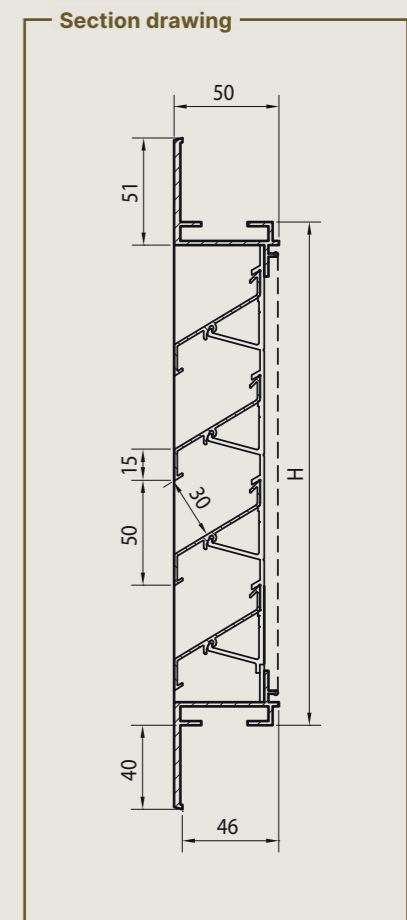

OUTSIDE
BUILT-IN

Material properties	Standard version	
Material	Aluminium, alloy EN AW-6063 T66	
Standard mesh type	Stainless steel 304 - 2.3 x 2.3 mm	
Surface treatment	Anodisation (20 microns), chemically etched F1-E6 natural colour	Polyester powder coating (60-80 micron) Seaside quality A & Standard powders
Wall bracket type	no. 1423 (included)	
Dimensions		
Blade pitch	50 mm	
Recess depth	46 mm	
Flange	40 mm	
Minimum dimensions (W x H)	150 x 150 mm	
Maximum width	4000 mm	
Maximum height	4000 mm	
Width and height cannot both exceed 2000 mm		
Maximum louvre surface area	6.9 m ²	

Our louvres come in a variety of dimensions, all of which can be used across most applications. When using large sizes in high-stress environments, such as at great heights, it is advisable to additionally verify the stability of the louvres and their mounting.

Available options

- **Counterframe:** Narrow counterframe for panel thicknesses from 41 mm to 54 mm
Deep counterframe for panel thicknesses from 55 mm to 88 mm
- **Mounting method:** Screw holes in flange frame
- **Custom flange:** Full surround or partial, with or without shortened flange
- **Closable:** With sliding vent
- **Operation:** Slider / Rotary knob / Cord / Rod / Linear actuator (230V or 24V)
- **Thermally insulated:** Sandwich panel on back, with or without opening for air duct connection
- **Finish:** Anodised: layer thickness 25 microns / other colours / other textures (E1-E10)
Powder coating: pre-treatment in accordance with Seaside OX (pre-anodisation) / non-standard powders
- **Other mesh types:** Mesh sizes 2.3 mm x 2.3 mm, 6 mm x 6 mm, 10 mm x 10 mm or 20 mm x 20 mm / Stainless steel grade AISI304 or AISI316 / No mesh
- **Special shapes / Water channel / Removable mesh / Filter / Drainage blade / Joining**

491

Aluminium stick-proof built-in louvre with 26% free area, Class A4

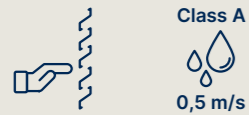
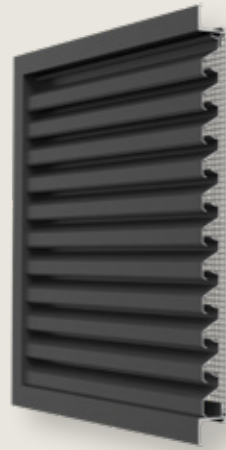

Class A
0,5 m/s

Material properties		Standard version	
Material	Aluminium, alloy EN AW-6063 T66		
Standard mesh type	Stainless steel 304 - 6 × 6 mm		
Surface treatment	Anodisation (20 microns), chemically etched F1-E6 natural colour	Polyester powder coating (60-80 micron) Seaside quality A & Standard powders	
Wall bracket type	no. 418 (included)		
Dimensions			
Blade pitch	33.3 mm		
Recess depth	29 mm		
Flange	21 mm		
Minimum dimensions (W x H)	100 × 100 mm		
Maximum width	4000 mm		
Maximum height	4000 mm		
Width and height cannot both exceed 2000 mm			
Maximum louvre surface area	7.9 m ²		

Our louvres come in a variety of dimensions, all of which can be used across most applications. When using large sizes in high-stress environments, such as at great heights, it is advisable to additionally verify the stability of the louvres and their mounting.

Performance								
Airflow rate								
Physical free area	26%							
Visual free area	56%							
Air supply	Resistance factor K	123.5						
	Flow coefficient C	0.090						
	Airflow rating	4						
Air extraction	Resistance factor K	118.1						
	Flow coefficient C	0.092						
	Airflow rating	4						
IP rating								
With mesh and water channel	IP44 (15 cm)*							
Water resistance %								
at (m/s)	0.0	0.5	1.0	1.5	2.0	2.5	3.0	3.5
With 2 × 2 mesh and water channel	A	A	C	D	D	D	D	-
	100	99.7	91.6	50.1	16.9	14.7	15.4	-

*Min. distance to electrical installation

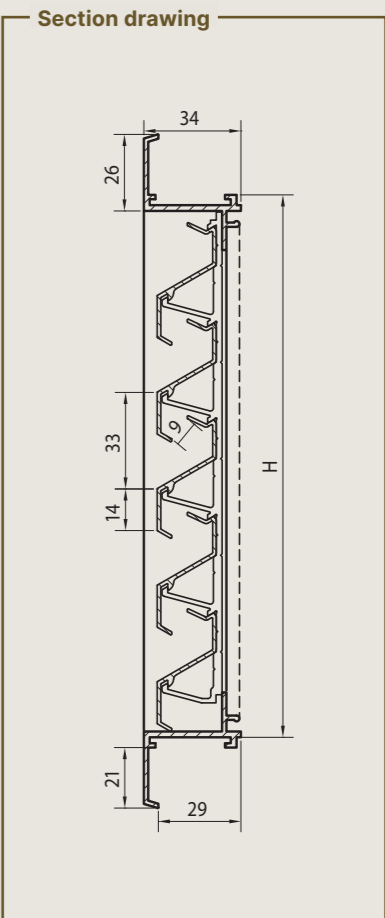

OUTSIDE
BUILT-IN

Available options

- **Counterframe:** Narrow counterframe for panel thicknesses from 23 mm to 45 mm
Deep counterframe for panel thicknesses from 46 mm to 71 mm
- **Mounting method:** Long dowels no. 418L / Clip springs no. 419 / Screw holes in flange frame
- **Custom flange:** Full surround or partial, with or without shortened flange
- **Closable:** With sliding vent
- **Operation:** Slider / Rotary knob / Cord / Rod / Linear actuator (230V or 24V)
- **Thermally insulated:** Sandwich panel on back, with or without opening for air duct connection
- **Finish:** Anodised: layer thickness 25 microns / other colours / other textures (E1-E10)
Powder coating: pre-treatment in accordance with Seaside OX (pre-anodisation) / non-standard powders
- **Other mesh types:** Mesh sizes 2.3 mm x 2.3 mm, 6 mm x 6 mm, 10 mm x 10 mm or 20 mm x 20 mm / Stainless steel grade AISI304 or AISI316 / No mesh
- **Special shapes / Blades welded into place in frame / Water channel / Removable mesh / Filter / Drainage blade / Joining**

GLAZED-IN FOR OUTSIDE APPLICATIONS



OUTSIDE
GLAZED-IN

414

Aluminium rain-resistant glazed-in louvre with 50% free area, Class A3

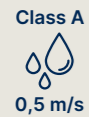

Material properties		Standard version	
Material	Aluminium, alloy EN AW-6063 T66		
Standard mesh type	Stainless steel 304 - 2.3 x 2.3 mm		
Surface treatment	Anodisation (20 microns), chemically etched F1-E6 natural colour	Polyester powder coating (60-80 micron) Seaside quality A & Standard powders	
Dimensions			
Blade pitch	33.3 mm		
Depth	34 mm		
Frame thickness available as standard	24, 28, 32 mm		
Minimum dimensions (W x H)	130 x 130 mm		
Maximum width	4000 mm		
Maximum	4000 mm		
Width and height cannot both exceed 2000 mm			
Maximum louvre surface area	8 m ²		

Our louvres come in a variety of dimensions, all of which can be used across most applications. When using large sizes in high-stress environments, such as at great heights, it is advisable to additionally verify the stability of the louvres and their mounting.

Performance								
Airflow rate								
Physical free area	50%							
Visual free area	59%							
Air supply	Resistance factor K	18.9						
	Flow coefficient C	0.230						
	Airflow rating	3						
Air extraction	Resistance factor K	19.8						
	Flow coefficient C	0.225						
	Airflow rating	3						
IP rating								
With mesh and water channel	IP23D (32 cm)*							
Without water channel	IP23D (33 cm)*							
Water resistance %								
at (m/s)	0.0	0.5	1.0	1.5	2.0	2.5	3.0	3.5
With 2 x 2 mesh and water channel	A	A	B	D	D	D	D	D
	99.5	99.0	96.5	78.9	41.9	23.6	15.2	10.4
Without water channel	B	C	C	D	D	D	D	D
	95.3	91.0	80.5	46.6	22.0	7.4	7.3	7.5

*Min. distance to electrical installation

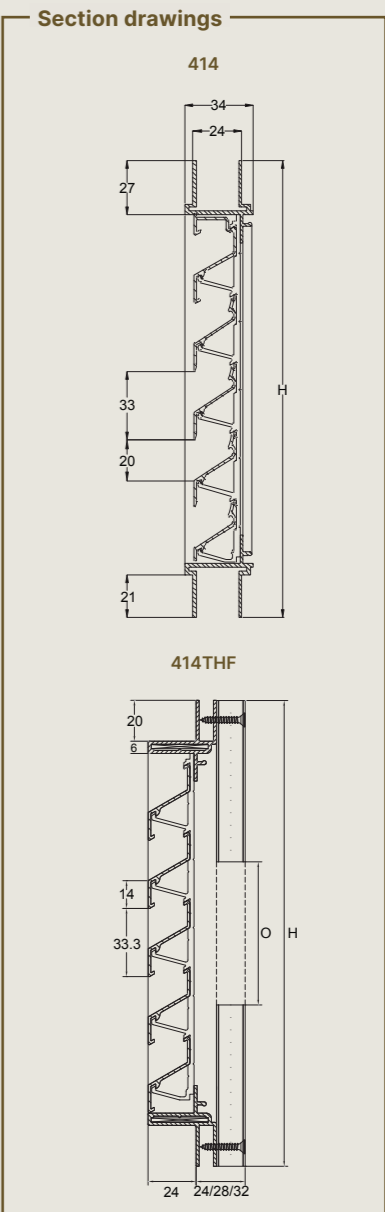

OUTSIDE
GLAZED-IN

Available options

- Custom glass thickness:** Minimum 8 mm and maximum 80 mm
- Closable:** With sliding vent / With insulated hatch
- Operation:** Slider / Rotary knob / Cord / Rod / Linear actuator (230V or 24V)
- Thermally insulated:** Sandwich panel on back, with or without opening for air duct connection / THF: sandwich panel running into window rebate
- Finish:** Anodised: layer thickness 25 microns / other colours / other textures (E1-E10)
Powder coating: pre-treatment in accordance with Seaside OX (pre-anodisation) / non-standard powders
- Other mesh types:** Mesh sizes 2.3 mm x 2.3 mm, 6 mm x 6 mm, 10 mm x 10 mm or 20 mm x 20 mm / Stainless steel grade AISI304 or AISI316 / No mesh
- Special shapes / Water channel / Removable mesh / Filter / Drainage blade / Joining**

414R

Round aluminium rain-resistant glazed-in louvre with 40% free area, Class A3



Material properties		Standard version	
Material	Aluminium, alloy EN AW-6063 T66		
Standard mesh type	Stainless steel 304 - 2.3 × 2.3 mm		
Surface treatment	Anodisation (20 microns), chemically etched F1-E6 natural colour	Polyester powder coating (60-80 micron) Seaside quality A & Standard powders	
Dimensions			
Blade pitch	33.3 mm		
Depth	36 mm		
Frame thickness available as standard	24 mm		
Minimum diameter	340 mm		
Maximum diameter	1500 mm		

Our louvres come in a variety of dimensions, all of which can be used across most applications. When using large sizes in high-stress environments, such as at great heights, it is advisable to additionally verify the stability of the louvres and their mounting.

Performance								
Airflow rate								
Physical free area		40%						
Visual free area		59%						
Air supply	Resistance factor K	22.7						
	Flow coefficient C	0.210						
	Airflow rating	3						
Air extraction	Resistance factor K	25.3						
	Flow coefficient C	0.199						
	Airflow rating	4						
IP rating								
Without water channel		IP2XD (10cm)*						
Water resistance %								
at (m/s)	0.0	0.5	1.0	1.5	2.0	2.5	3.0	3.5
Without water channel	A	A	B	C	D	D	D	D
	99.6	99.1	97.3	84.2	50.0	24.5	15.4	13.4

*Min. distance to electrical installation

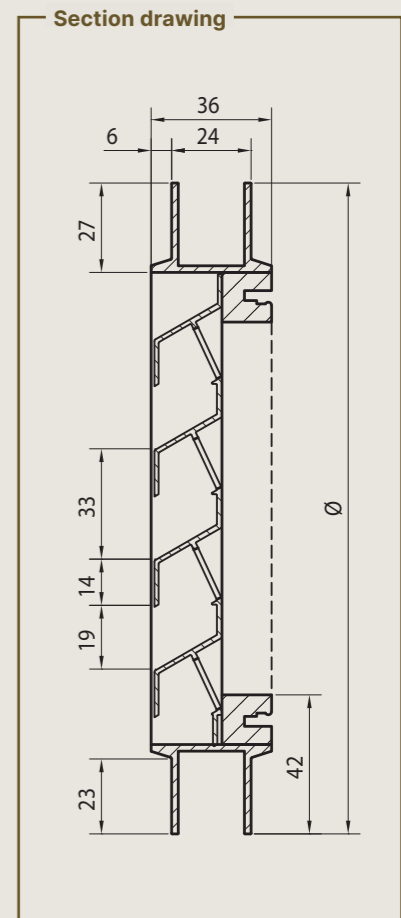

OUTSIDE
GLAZED-IN

Available options

- **Thermally insulated:** Sandwich panel on back, with or without opening for air duct connection
- **Finish:** Anodised: layer thickness 25 microns / other colours / other textures (E1-E10)
Powder coating: pre-treatment in accordance with Seaside OX (pre-anodisation) / non-standard powders
- **Other mesh types:** Mesh sizes 2.3 mm x 2.3 mm, 6 mm x 6 mm, 10 mm x 10 mm or 20 mm x 20 mm / Stainless steel grade AISI304 or AISI316 / No mesh

415

Aluminium stick-proof glazed-in louvre with 39% free area, Class A4, IP44

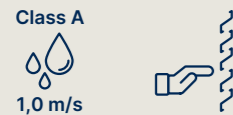

Material properties		Standard version	
Material	Aluminium, alloy EN AW-6063 T66		
Standard mesh type	Stainless steel 304 - 6 × 6 mm		
Surface treatment	Anodisation (20 microns), chemically etched F1-E6 natural colour	Polyester powder coating (60-80 micron) Seaside quality A & Standard powders	
Dimensions			
Blade pitch	20 mm		
Depth	34 mm		
Frame thickness available as standard	24, 28, 32 mm		
Minimum dimensions (W x H)	130 × 130 mm		
Maximum width	4000 mm		
Maximum height	4000 mm		
Width and height cannot both exceed 2000 mm			
Maximum louvre surface area	6.7 m ²		

Our louvres come in a variety of dimensions, all of which can be used across most applications. When using large sizes in high-stress environments, such as at great heights, it is advisable to additionally verify the stability of the louvres and their mounting.

Performance								
Airflow rate								
Physical free area	39%							
Visual free area	93%							
Air supply	Resistance factor K	34.6						
	Flow coefficient C	0.170						
	Airflow rating	4						
Air extraction	Resistance factor K	34.6						
	Flow coefficient C	0.170						
	Airflow rating	4						
IP rating								
With mesh and water channel	IP44 (35 cm)*							
Without water channel	IP2XD							
Water resistance %								
at (m/s)	0.0	0.5	1.0	1.5	2.0	2.5	3.0	3.5
With 2 x 2 mesh and water channel	A	A	A	B	C	D	-	-
	99.9	99.7	99.2	95.6	87.5	63.1	-	-
Without water channel	C	C	D	D	-	-	-	-
	90.4	81.6	68.8	40.4	-	-	-	-

*Min. distance to electrical installation

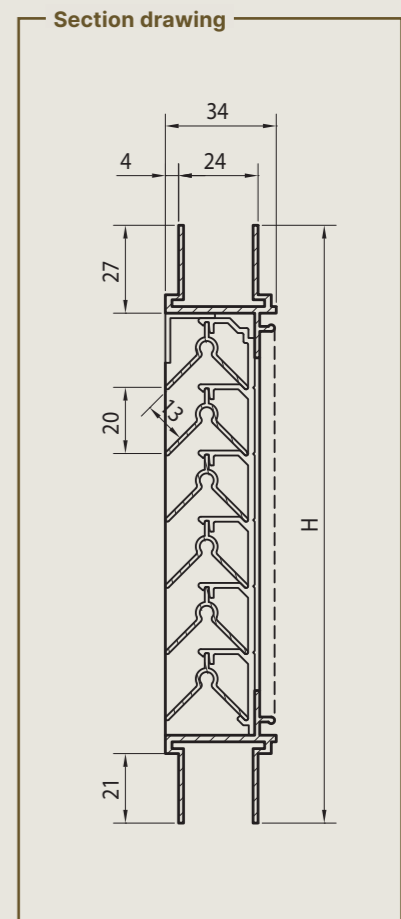

OUTSIDE
GLAZED-IN

Available options

- **Custom glass thickness:** Minimum 8 mm and maximum 80 mm
- **Closable:** With sliding vent / With insulated hatch
- **Operation:** Slider / Rotary knob / Cord / Rod / Linear actuator (230V or 24V)
- **Thermally insulated:** Sandwich panel on back, with or without opening for air duct connection / THF: sandwich panel running into window rebate
- **Finish:** Anodised: layer thickness 25 microns / other colours / other textures (E1-E10)
Powder coating: pre-treatment in accordance with Seaside OX (pre-anodisation) / non-standard powders
- **Other mesh types:** Mesh sizes 2.3 mm x 2.3 mm, 6 mm x 6 mm, 10 mm x 10 mm or 20 mm x 20 mm / Stainless steel grade AISI304 or AISI316 / No mesh
- **Special shapes / Water channel / Removable mesh / Filter / Drainage blade / Joining**

415R

Round aluminium stick-proof glazed-in louvre with 39% free area, Class A4



Material properties		Standard version	
Material	Aluminium, alloy EN AW-6063 T66		
Standard mesh type	Stainless steel 304 - 6 × 6 mm		
Surface treatment	Anodisation (20 microns), chemically etched F1-E6 natural colour	Polyester powder coating (60-80 micron) Seaside quality A & Standard powders	
Dimensions			
Blade pitch	20 mm		
Depth	42 mm		
Frame thickness available as standard	24 mm		
Minimum diameter	340 mm		
Maximum diameter	1500 mm		

Our louvres come in a variety of dimensions, all of which can be used across most applications. When using large sizes in high-stress environments, such as at great heights, it is advisable to additionally verify the stability of the louvres and their mounting.

Performance		
Airflow rate		
Physical free area		39%
Visual free area		93%
Air supply	Resistance factor K	34.6
	Flow coefficient C	0.170
	Airflow rating	4
Air extraction	Resistance factor K	34.6
	Flow coefficient C	0.170
	Airflow rating	4
IP rating		
With mesh and water channel		IP2XD
Without water channel		IP2XD

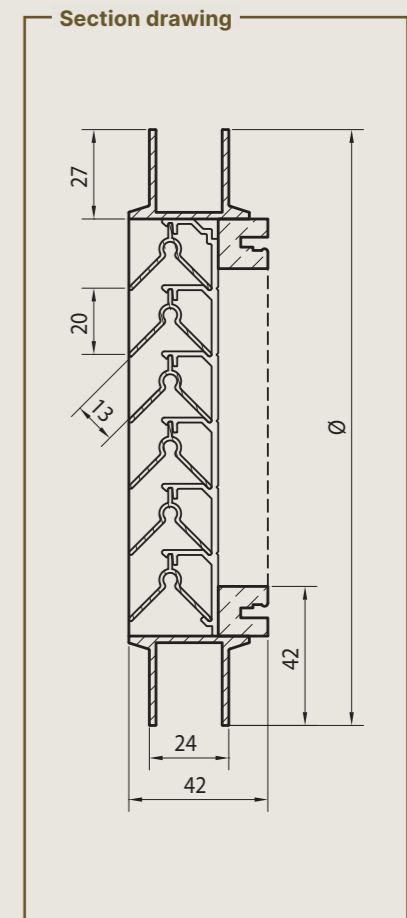

OUTSIDE
GLAZED-IN

Available options

- **Thermally insulated:** Sandwich panel on back, with or without opening for air duct connection
- **Finish:** Anodised: layer thickness 25 microns / other colours / other textures (E1-E10)
Powder coating: pre-treatment in accordance with Seaside OX (pre-anodisation) / non-standard powders
- **Other mesh types:** Mesh sizes 2.3 mm x 2.3 mm, 6 mm x 6 mm, 10 mm x 10 mm or 20 mm x 20 mm / Stainless steel grade AISI304 or AISI316 / No mesh

424

Aluminium glazed-in louvre with 49% free area, Class B3

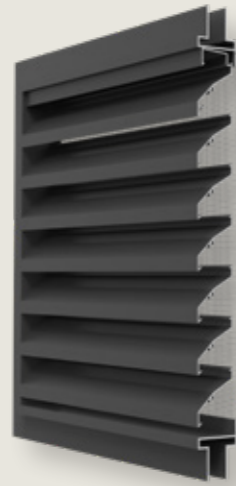

Performance								
Airflow rate								
Physical free area	49%							
Visual free area	70%							
Air supply	Resistance factor K	12.1						
	Flow coefficient C	0.287						
	Airflow rating	3						
Air extraction	Resistance factor K	12.1						
	Flow coefficient C	0.287						
	Airflow rating	3						
IP rating								
With mesh and water channel	IP2XD (10 cm)*							
Without water channel	IP2XD (10 cm)*							
Water resistance %								
at (m/s)	0.0	0.5	1.0	1.5	2.0	2.5	3.0	3.5
With 2 x 2 mesh and water channel	B	C	C	C	D	D	D	D
	95	92.2	89.8	84.5	72.6	56.7	44.4	33.7
Without water channel	C	C	D	D	D	D	D	D
	91.4	86.2	78.9	65.8	45.3	26.4	13.7	1.8

*Min. distance to electrical installation

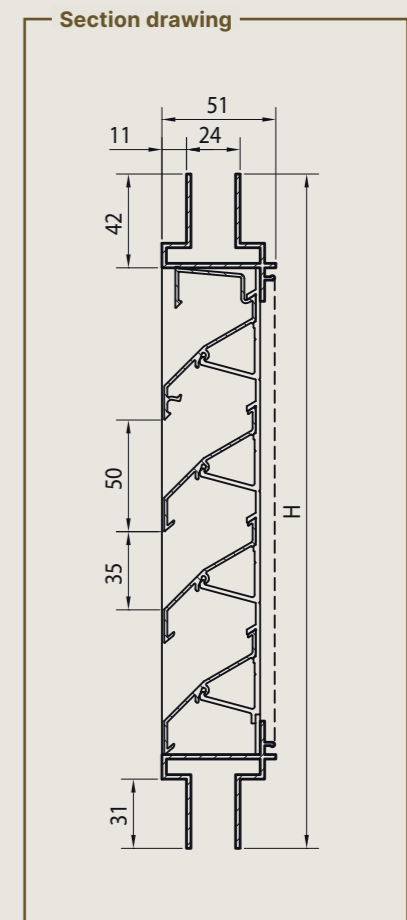

OUTSIDE
GLAZED-IN

Material properties	Standard version	
Material	Aluminium, alloy EN AW-6063 T66	
Standard mesh type	Stainless steel 304 - 2.3 x 2.3 mm	
Surface treatment	Anodisation (20 microns), chemically etched F1-E6 natural colour	Polyester powder coating (60-80 micron) Seaside quality A & Standard powders
Dimensions		
Blade pitch	50 mm	
Depth	51 mm	
Frame thickness available as standard	24, 28 mm	
Minimum dimensions (W x H)	220 x 220 mm	
Maximum width	4000 mm	
Maximum height	4000 mm	
Width and height cannot both exceed 2000 mm		
Maximum louvre surface area	6 m ²	

Our louvres come in a variety of dimensions, all of which can be used across most applications. When using large sizes in high-stress environments, such as at great heights, it is advisable to additionally verify the stability of the louvres and their mounting.

Available options

- Custom glass thickness:** Minimum 8 mm and maximum 80 mm
- Thermally insulated:** Sandwich panel on back, with or without opening for air duct connection
- Finish:** Anodised: layer thickness 25 microns / other colours / other textures (E1-E10)
Powder coating: pre-treatment in accordance with Seaside OX (pre-anodisation) / non-standard powders
- Closable:** With sliding vent
- Operation:** Slider / Rotary knob / Cord / Rod / Linear actuator (230V or 24V)
- Other mesh types:** Mesh sizes 2.3 mm x 2.3 mm, 6 mm x 6 mm, 10 mm x 10 mm or 20 mm x 20 mm / Stainless steel grade AISI304 or AISI316 / No mesh
- Special shapes / Water channel / Removable mesh / Filter / Drainage blade / Joining**

424RC2

Aluminium burglar-resistant glazed-in louvre, Class RC2



Material properties		Standard version	
Material	Aluminium, alloy EN AW-6063 T66		
Standard mesh type	Stainless steel 304 - 2.3 × 2.3 mm		
Surface treatment	Anodisation (20 microns), chemically etched F1-E6 natural colour	Polyester powder coating (60-80 micron) Seaside quality A & Standard powders	
Dimensions			
Blade pitch	50 mm		
Depth	51 mm		
Frame thickness available as standard	24, 28 mm		
Minimum dimensions (W x H)	220 × 246 mm		
Maximum width	4000 mm		
Maximum height	4000 mm		
Width and height cannot both exceed 2000 mm			
Maximum louvre surface area	5 m ²		

Our louvres come in a variety of dimensions, all of which can be used across most applications. When using large sizes in high-stress environments, such as at great heights, it is advisable to additionally verify the stability of the louvres and their mounting.

Performance		
Airflow rate		
Physical free area	46 %	
Visual free area	70%	
Air supply	Resistance factor K	12.9
	Flow coefficient C	0.278
	Airflow rating	3
Air extraction	Resistance factor K	12.2
	Flow coefficient C	0.286
	Airflow rating	3
IP rating		
With mesh and water channel	IP3XD (20 cm)*	
Without water channel	IP2XD (10 cm)*	

*Min. distance to electrical installation

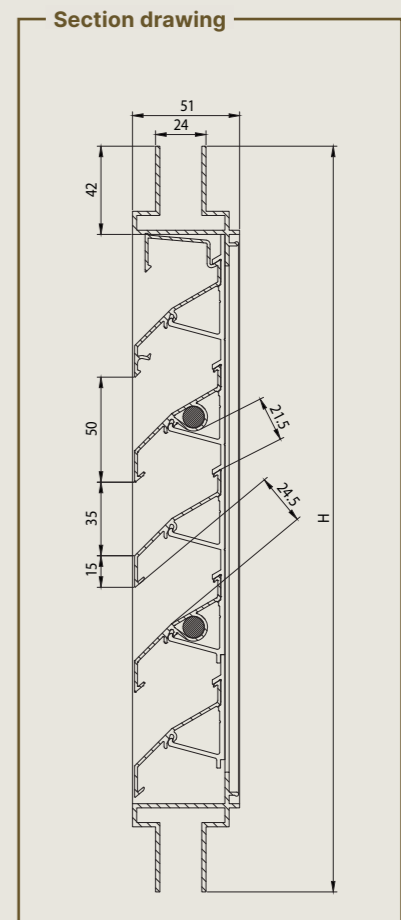

OUTSIDE
GLAZED-IN

Available options

- **Custom glass thickness:** Minimum 8 mm and maximum 50 mm
- **Thermally insulated:** Sandwich panel on back, with or without opening for air duct connection
- **Finish:** Anodised: layer thickness 25 microns / other colours / other textures (E1-E10)
Powder coating: pre-treatment in accordance with Seaside OX (pre-anodisation) / non-standard powders
- **Closable:** With sliding vent
- **Operation:** Slider / Rotary knob / Cord / Rod / Linear actuator (230V or 24V)
- **Other mesh types:** Mesh sizes 2.3 mm x 2.3 mm, 6 mm x 6 mm, 10 mm x 10 mm or 20 mm x 20 mm / Stainless steel grade AISI304 or AISI316 / No mesh
- **Water channel / Removable mesh / Filter / Drainage blade**

427GL

Aluminium adjustable glazed-in louvre

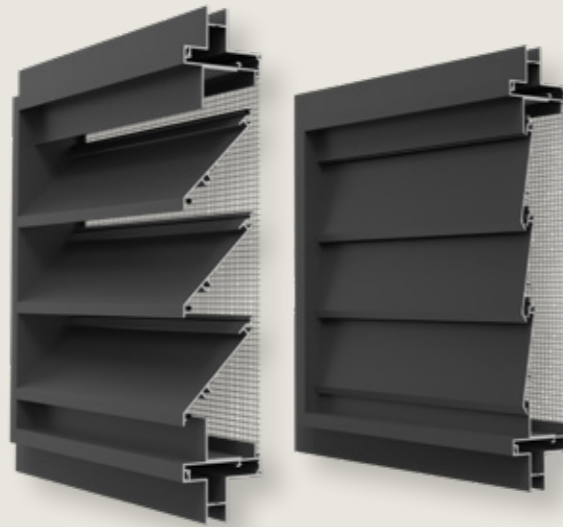

Performance		
Airflow rate		
Physical free area		53%
Visual free area		88%
Air supply	Resistance factor K	11.4
	Flow coefficient C	0.296
	Airflow rating	3
Air extraction	Resistance factor K	11.7
	Flow coefficient C	0.293
	Airflow rating	3

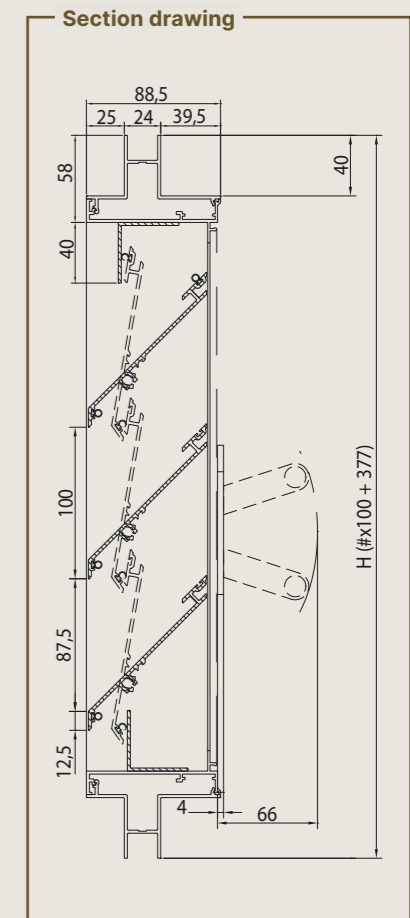

OUTSIDE
GLAZED-IN

Material properties		Standard version	
Material	Aluminium, alloy EN AW-6063 T66		
Standard mesh type	Stainless steel 304 - 6 × 6 mm		
Surface treatment	Anodisation (20 microns), chemically etched F1-E6 natural colour	Polyester powder coating (60-80 micron) Seaside quality A & Standard powders	
Dimensions			
Blade pitch	100 mm		
Depth	89 mm		
Frame thickness available as standard	24 mm		
Minimum dimensions (W x H)	377 × 377 mm		
Maximum width	1300 mm		
Maximum height	1990 mm		
Preferred height	377 mm + (n x 100)		
Maximum louvre surface area	2.6 m ²		

Our louvres come in a variety of dimensions, all of which can be used across most applications. When using large sizes in high-stress environments, such as at great heights, it is advisable to additionally verify the stability of the louvres and their mounting.

Available options

- **Custom glass thickness:** Minimum 8 mm and maximum 80 mm
- **Closable**
- **Control:** 427/1: Manual / 427/2: Cable / 427/3: Ultraflex / 427/4: 230V or 24V linear actuator / 427/5: Pneumatic / 427/6: 230V or 24V fire damper actuator
- **Finish:** Anodised: layer thickness 25 microns / other colours / other textures (E1-E10)
Powder coating: pre-treatment in accordance with Seaside OX (pre-anodisation) / non-standard powders
- **Other mesh types:** Mesh sizes 2.3 mm x 2.3 mm, 6 mm x 6 mm, 10 mm x 10 mm or 20 mm x 20 mm / Stainless steel grade AISI304 or AISI316 / No mesh
- **Drainage blade**

483

Aluminium glazed-in louvre with 76% free area, deep version



Performance								
Airflow rate								
Physical free area		76%						
Visual free area		90%						
Air supply	Resistance factor K	4.6						
	Flow coefficient C	0.466						
	Airflow rating	1						
Air extraction	Resistance factor K	5.2						
	Flow coefficient C	0.439						
	Airflow rating	1						
IP rating								
With mesh and water channel		IP2XD (18 cm)*						
Water resistance %								
at (m/s)	0.0	0.5	1.0	1.5	2.0	2.5	3.0	3.5
With 2 x 2 mesh and water channel	C	C	C	C	D	D	-	-
	90.1	87.3	84.2	80.1	73.4	62.0	-	-
Without water channel	D	D	D	D	D	D	D	D
	75.9	68.9	62.8	56.9	51.7	45.5	39.4	30.4

*Min. distance to electrical installation

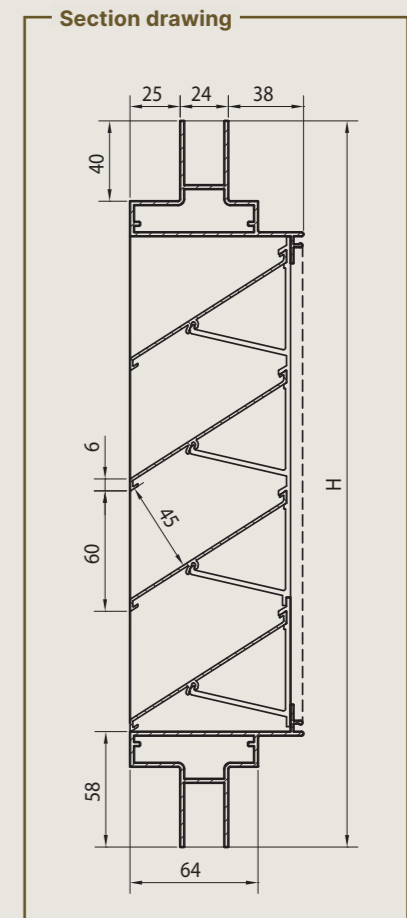

OUTSIDE
GLAZED-IN

Material properties	Standard version	
Material	Aluminium, alloy EN AW-6063 T66	
Standard mesh type	Stainless steel 304 - 6 x 6 mm	
Surface treatment	Anodisation (20 microns), chemically etched F1-E6 natural colour	Polyester powder coating (60-80 micron) Seaside quality A & Standard powders
Dimensions		
Blade pitch	60 mm	
Depth	87 mm	
Frame thickness available as standard	24 mm	
Minimum dimensions (W x H)	385 x 385 mm	
Maximum width	4000 mm	
Maximum height	4000 mm	
Width and height cannot both exceed 2000 mm		
Maximum louvre surface area	5.9 m ²	

Our louvres come in a variety of dimensions, all of which can be used across most applications. When using large sizes in high-stress environments, such as at great heights, it is advisable to additionally verify the stability of the louvres and their mounting.

Available options

- Custom glass thickness:** Minimum 8 mm and maximum 80 mm
- Thermally insulated:** Sandwich panel on back, with or without opening for air duct connection
- Finish:** Anodised: layer thickness 25 microns / other colours / other textures (E1-E10)
Powder coating: pre-treatment in accordance with Seaside OX (pre-anodisation) / non-standard powders
- Closable:** With sliding vent
- Operation:** Slider / Rotary knob / Cord / Rod / Linear actuator (230V or 24V)
- Other mesh types:** Mesh sizes 2.3 mm x 2.3 mm, 6 mm x 6 mm, 10 mm x 10 mm or 20 mm x 20 mm / Stainless steel grade AISI304 or AISI316 / No mesh
- Special shapes / Water channel / Removable mesh / Filter / Drainage blade / Joining**

484

Aluminium glazed-in louvre with 60% free area, Class B2



Performance								
Airflow rate								
Physical free area	60%							
Visual free area	70%							
Air supply	Resistance factor K	8.2						
	Flow coefficient C	0.349						
	Airflow rating	2						
Air extraction	Resistance factor K	9.8						
	Flow coefficient C	0.319						
	Airflow rating	2						
IP rating								
With mesh and water channel	IP2XD (10.5 cm)*							
Water resistance %								
at (m/s)	0.0	0.5	1.0	1.5	2.0	2.5	3.0	3.5
With 2 x 2 mesh and water channel	B	C	C	C	D	D	D	D
	96.0	94.3	92.2	88.2	76.9	57.3	42.4	33.0
Without water channel	C	C	C	D	D	D	D	D
	90.6	86.4	80.8	72.0	51.4	31.8	22.0	13.7

*Min. distance to electrical installation

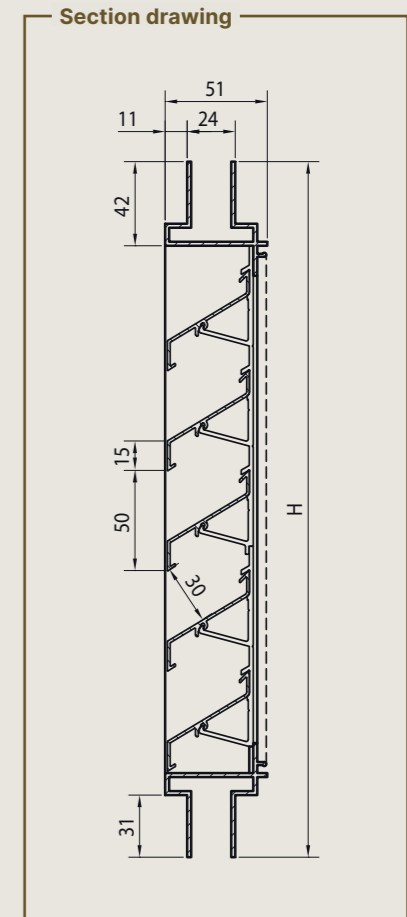

OUTSIDE
GLAZED-IN

Material properties	Standard version	
Material	Aluminium, alloy EN AW-6063 T66	
Standard mesh type	Stainless steel 304 - 2.3 x 2.3 mm	
Surface treatment	Anodisation (20 microns), chemically etched F1-E6 natural colour	Polyester powder coating (60-80 micron) Seaside quality A & Standard powders
Dimensions		
Blade pitch	50 mm	
Depth	51 mm	
Frame thickness available as standard	24, 28 mm	
Minimum dimensions (W x H)	220 x 220 mm	
Maximum width	4000 mm	
Maximum height	4000 mm	
Width and height cannot both exceed 2000 mm		
Maximum louvre surface area	6.9 m ²	

Our louvres come in a variety of dimensions, all of which can be used across most applications. When using large sizes in high-stress environments, such as at great heights, it is advisable to additionally verify the stability of the louvres and their mounting.

Available options

- **Custom glass thickness:** Minimum 8 mm and maximum 80 mm
- **Thermally insulated:** Sandwich panel on back, with or without opening for air duct connection
- **Finish:** Anodised: layer thickness 25 microns / other colours / other textures (E1-E10)
Powder coating: pre-treatment in accordance with Seaside OX (pre-anodisation) / non-standard powders
- **Closable:** With sliding vent
- **Operation:** Slider / Rotary knob / Cord / Rod / Linear actuator (230V or 24V)
- **Other mesh types:** Mesh sizes 2.3 mm x 2.3 mm, 6 mm x 6 mm, 10 mm x 10 mm or 20 mm x 20 mm / Stainless steel grade AISI304 or AISI316 / No mesh
- **Special shapes / Water channel / Removable mesh / Filter / Drainage blade / Joining**

494

Aluminium stick-proof glazed-in louvre with 26% free area, Class A4



Material properties		Standard version	
Material	Aluminium, alloy EN AW-6063 T66		
Standard mesh type	Stainless steel 304 - 6 × 6 mm		
Surface treatment	Anodisation (20 microns), chemically etched F1-E6 natural colour	Polyester powder coating (60-80 micron) Seaside quality A & Standard powders	
Dimensions			
Blade pitch	33.3 mm		
Depth	34 mm		
Frame thickness available as standard	24, 28, 32 mm		
Minimum dimensions (W x H)	130 × 130 mm		
Maximum width	4000 mm		
Maximum height	4000 mm		
Width and height cannot both exceed 2000 mm			
Maximum louvre surface area	7.9 m ²		

Our louvres come in a variety of dimensions, all of which can be used across most applications. When using large sizes in high-stress environments, such as at great heights, it is advisable to additionally verify the stability of the louvres and their mounting.

Performance								
Airflow rate								
Physical free area		26%						
Visual free area		56%						
Air supply	Resistance factor K	123.5						
	Flow coefficient C	0.090						
	Airflow rating	4						
Air extraction	Resistance factor K	118.1						
	Flow coefficient C	0.092						
	Airflow rating	4						
IP rating								
With mesh and water channel		IP44 (15 cm)*						
Water resistance %								
at (m/s)	0.0	0.5	1.0	1.5	2.0	2.5	3.0	3.5
With 2 × 2 mesh and water channel	A	A	C	D	D	D	D	-
	100	99.7	91.6	50.1	16.9	14.7	15.4	-

*Min. distance to electrical installation

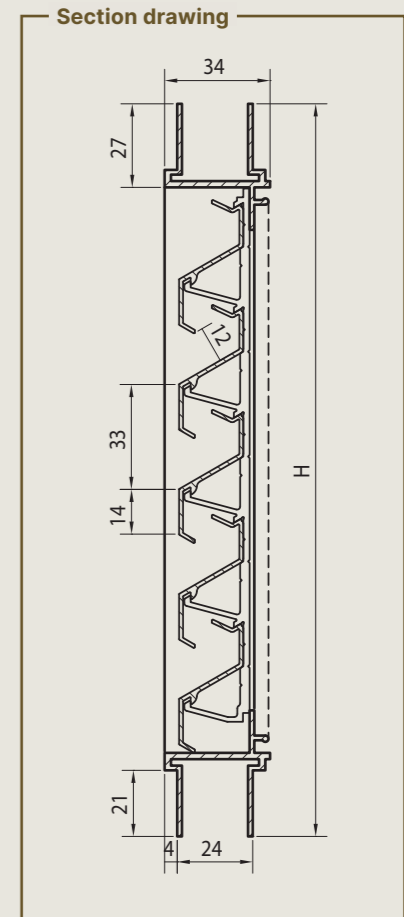

OUTSIDE
GLAZED-IN

Available options

- Custom glass thickness:** Minimum 8 mm and maximum 80 mm
- Thermally insulated:** Sandwich panel on back, with or without opening for air duct connection
- Finish:** Anodised: layer thickness 25 microns / other colours / other textures (E1-E10)
Powder coating: pre-treatment in accordance with Seaside OX (pre-anodisation) / non-standard powders
- Closable:** With sliding vent
- Operation:** Slider / Rotary knob / Cord / Rod / Linear actuator (230V or 24V)
- Other mesh types:** Mesh sizes 2.3 mm x 2.3 mm, 6 mm x 6 mm, 10 mm x 10 mm or 20 mm x 20 mm / Stainless steel grade AISI304 or AISI316 / No mesh
- Special shapes / Water channel / Removable mesh / Filter / Drainage blade / Joining**

SURFACE-MOUNTED LOUVRES FOR OUTSIDE APPLICATIONS



OUTDOOR
SURFACE MOUNTED

431

Aluminium rain-resistant surface-mounted louvre with 50% free area, Class A3



Depending on the type of surface to which the louvre is attached, different types of mounting materials may be appropriate. If no mounting materials were supplied, or if the supplied materials are not suitable for the application, the installer must provide the correct materials

Material properties		Standard version	
Material	Aluminium, alloy EN AW-6063 T66		
Standard mesh type	Stainless steel 304 - 2.3 × 2.3 mm		
Surface treatment	Anodisation (20 microns), chemically etched F1-E6 natural colour	Polyester powder coating (60-80 micron) Seaside quality A & Standard powders	
Dimensions			
Blade pitch	33.3 mm		
Depth	29 mm		
Minimum dimensions (W x H)	120 × 120 mm		
Maximum width	4000 mm		
Maximum height	4000 mm		
Width and height cannot both exceed 2000 mm			
Maximum louvre surface area	8 m ²		

Our louvres come in a variety of dimensions, all of which can be used across most applications. When using large sizes in high-stress environments, such as at great heights, it is advisable to additionally verify the stability of the louvres and their mounting.

Performance								
Airflow rate								
Physical free area		50%						
Visual free area		59%						
Air supply	Resistance factor K	18.9						
	Flow coefficient C	0.230						
	Airflow rating	3						
Air extraction	Resistance factor K	19.8						
	Flow coefficient C	0.225						
	Airflow rating	3						
IP rating								
With mesh and water channel		IP23D (32 cm)*						
Without water channel		IP23D (33 cm)*						
Water resistance %								
at (m/s)	0.0	0.5	1.0	1.5	2.0	2.5	3.0	3.5
With 2 × 2 mesh and water channel	A	A	B	D	D	D	D	D
	99.5	99.0	96.5	78.9	41.9	23.6	15.2	10.4
Without water channel	B	C	C	D	D	D	D	D
	95.3	91.0	80.5	46.6	22.0	7.4	7.3	7.5

*Min. distance to electrical installation

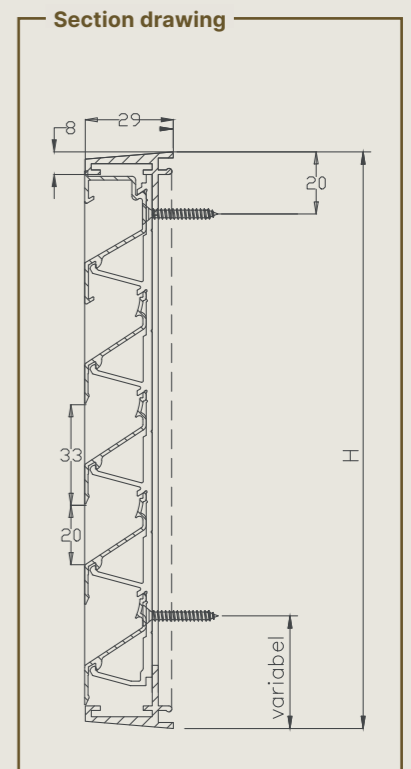

OUTDOOR
SURFACE MOUNTED

Stock models							
Dimensions (W x H) mm	Natural colour anodised F1	Renson standard white	STR 7016	STR 9005	Flow rate at 2 Pa (m ³ /h)	Flow rate at 10 Pa (m ³ /h)	Flow rate at 20 Pa (m ³ /h)
165 × 165	10465	13902	11974	10466	23	51.4	72.7
225 × 225	11931	10468	10467	17401	50	111.8	158.1
325 × 325	11932	9137	-	-	118	263.9	373.1
425 × 425	17366	-	-	-	215	480.8	679.9
525 × 525	17367	-	-	-	341	762.5	1078.3

Available options	
• Finish:	Anodised: layer thickness 25 microns / other colours / other textures (E1-E10) Powder coating: pre-treatment in accordance with Seaside OX (pre-anodisation) / non-standard powders
• Other mesh types:	Mesh sizes 2.3 mm x 2.3 mm, 6 mm x 6 mm, 10 mm x 10 mm or 20 mm x 20 mm / Stainless steel grade AISI304 or AISI316 / No mesh
• Special shapes	

431R

Round aluminium rain-resistant surface-mounted louvre with 40% free area, Class A3

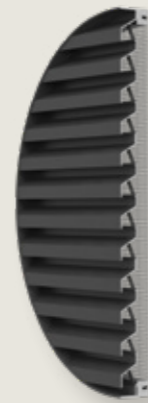

Depending on the type of surface to which the louvre is attached, different types of mounting materials may be appropriate. If no mounting materials were supplied, or if the supplied materials are not suitable for the application, the installer must provide the correct materials

Material properties		Standard version	
Material	Aluminium, alloy EN AW-6063 T66		
Standard mesh type	Stainless steel 304 - 2.3 × 2.3 mm		
Surface treatment	Anodisation (20 microns), chemically etched F1-E6 natural colour	Polyester powder coating (60-80 micron) Seaside quality A & Standard powders	
Dimensions			
Blade pitch	33.3 mm		
Depth	40 mm		
Minimum diameter	300 mm		
Maximum diameter	1500 mm		

Our louvres come in a variety of dimensions, all of which can be used across most applications. When using large sizes in high-stress environments, such as at great heights, it is advisable to additionally verify the stability of the louvres and their mounting.

Performance								
Airflow rate								
Physical free area		40%						
Visual free area		59%						
Air supply	Resistance factor K	22.7						
	Flow coefficient C	0.210						
	Airflow rating	3						
Air extraction	Resistance factor K	25.3						
	Flow coefficient C	0.199						
	Airflow rating	4						
IP rating								
Without water channel		IP2XD (10 cm)*						
Water resistance %								
at (m/s)	0.0	0.5	1.0	1.5	2.0	2.5	3.0	3.5
Without water channel	A	A	B	C	D	D	D	D
	99.6	99.1	97.3	84.2	50	24.5	15.4	13.4

*Min. distance to electrical installation

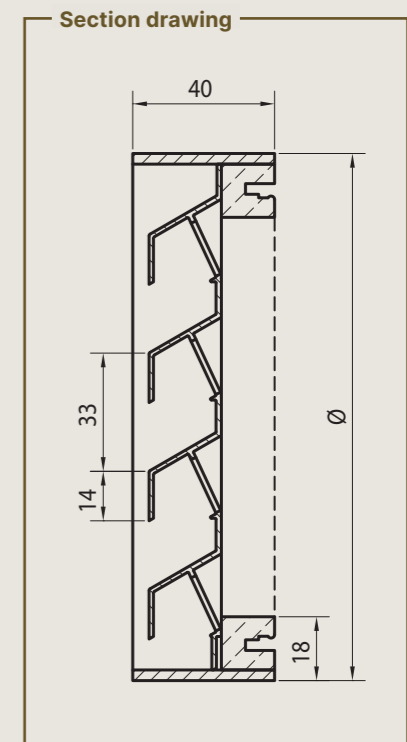

OUTDOOR
SURFACE MOUNTED

Available options

- Finish:** Anodised: layer thickness 25 microns / other colours / other textures (E1-E10)
 Powder coating: pre-treatment in accordance with Seaside OX (pre-anodisation) / non-standard powders
- Other mesh types:** Mesh sizes 2.3 mm x 2.3 mm, 6 mm x 6 mm, 10 mm x 10 mm or 20 mm x 20 mm / Stainless steel grade AISI304 or AISI316 / No mesh

431RC2

Aluminium fall-proof and burglar-resistant surface-mounted louvre, Class RC2



Class A
0,5 m/s



Depending on the type of surface to which the louvre is attached, different types of mounting materials may be appropriate. If no mounting materials were supplied, or if the supplied materials are not suitable for the application, the installer must provide the correct materials.'

Material properties		Standard version	
Material	Aluminium, alloy EN AW-6063 T66		
Standard mesh type	Stainless steel 304 - 2.3 x 2.3 mm		
Surface treatment	Anodisation (20 microns), chemically etched F1-E6 natural colour	Polyester powder coating (60-80 micron) Seaside quality A & Standard powders	
Dimensions			
Blade pitch	33.3 mm		
Depth	31 mm		
Minimum dimensions (W x H)	170 x 170 mm		
Maximum width	4000 mm		
Maximum height	4000 mm		
Width and height cannot both exceed 2000 mm			
Maximum louvre surface area	4.7m ²		

Our louvres come in a variety of dimensions, all of which can be used across most applications. When using large sizes in high-stress environments, such as at great heights, it is advisable to additionally verify the stability of the louvres and their mounting.

Performance								
Airflow rate								
Physical free area			40%					
Visual free area			59%					
Air supply	Resistance factor K		22.7					
	Flow coefficient C		0.210					
	Airflow rating		3					
Air extraction	Resistance factor K		25.3					
	Flow coefficient C		0.199					
	Airflow rating		4					
Water resistance %								
at (m/s)	0.0	0.5	1.0	1.5	2.0	2.5	3.0	3.5
Without water channel	A	A	B	C	D	D	D	D
	99.6	99.1	97.3	84.2	50	24.5	15.4	13.4
Fall-through safety								
EN 13049:2003			Class 5					

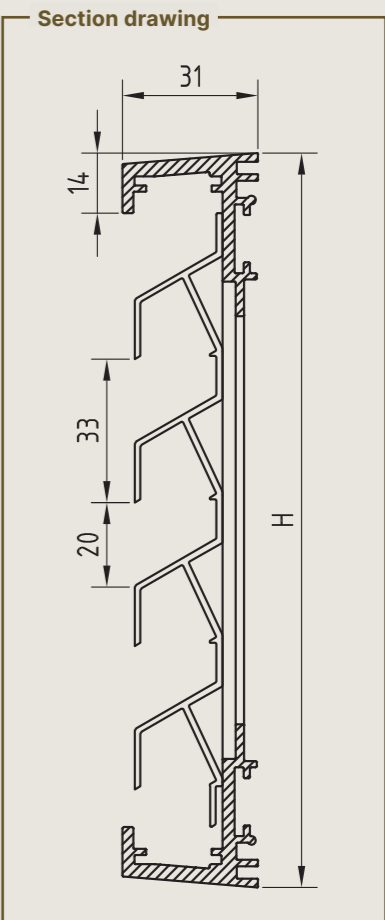

OUTDOOR
SURFACE MOUNTED

Available options

- Finish:** Anodised: layer thickness 25 microns / other colours / other textures (E1-E10)
 Powder coating: pre-treatment in accordance with Seaside OX (pre-anodisation) / non-standard powders
- Other mesh types:** Mesh sizes 2.3 mm x 2.3 mm, 6 mm x 6 mm, 10 mm x 10 mm or 20 mm x 20 mm / Stainless steel grade AISI304 or AISI316 / No mesh

432

Aluminium rain-resistant removable surface-mounted louvre with 50% free area, Class A3

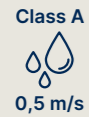
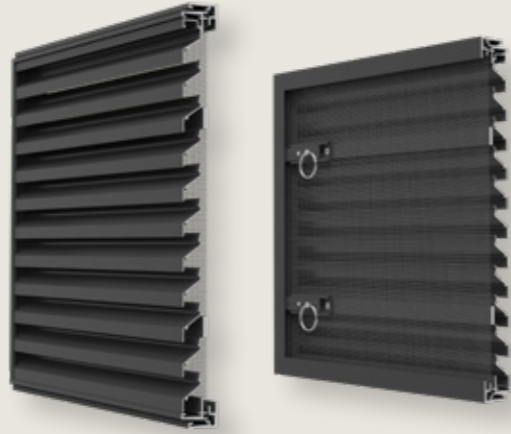

Depending on the type of surface to which the louvre is attached, different types of mounting materials may be appropriate. If no mounting materials were supplied, or if the supplied materials are not suitable for the application, the installer must provide the correct materials.*

Material properties		Standard version	
Material	Aluminium, alloy EN AW-6063 T66		
Standard mesh type	Stainless steel 304 - 2.3 x 2.3 mm		
Surface treatment	Anodisation (20 microns), chemically etched F1-E6 natural colour	Polyester powder coating (60-80 micron) Seaside quality A & Standard powders	
Dimensions			
Blade pitch	33.3 mm		
Depth	40 mm		
Minimum dimensions (W x H)	150 x 150 mm		
Maximum width	3000 mm		
Maximum height	3000 mm		
Maximum louvre surface area	2.3 m ²		

Our louvres come in a variety of dimensions, all of which can be used across most applications. When using large sizes in high-stress environments, such as at great heights, it is advisable to additionally verify the stability of the louvres and their mounting.

Performance								
Airflow rate								
Physical free area		50%						
Visual free area		59%						
Air supply	Resistance factor K	18.9						
	Flow coefficient C	0.230						
	Airflow rating	3						
Air extraction	Resistance factor K	19.8						
	Flow coefficient C	0.225						
	Airflow rating	3						
IP rating								
With mesh and water channel		IP23D (32 cm)*						
Without water channel		IP23D (33 cm)*						
Water resistance %								
at (m/s)	0.0	0.5	1.0	1.5	2.0	2.5	3.0	3.5
With 2 x 2 mesh and water channel	A	A	B	D	D	D	D	D
	99.5	99.0	96.5	78.9	41.9	23.6	15.2	10.4
Without water channel	B	C	C	D	D	D	D	D
	95.3	91.0	80.5	46.6	22.0	7.4	7.3	7.5

*Min. distance to electrical installation

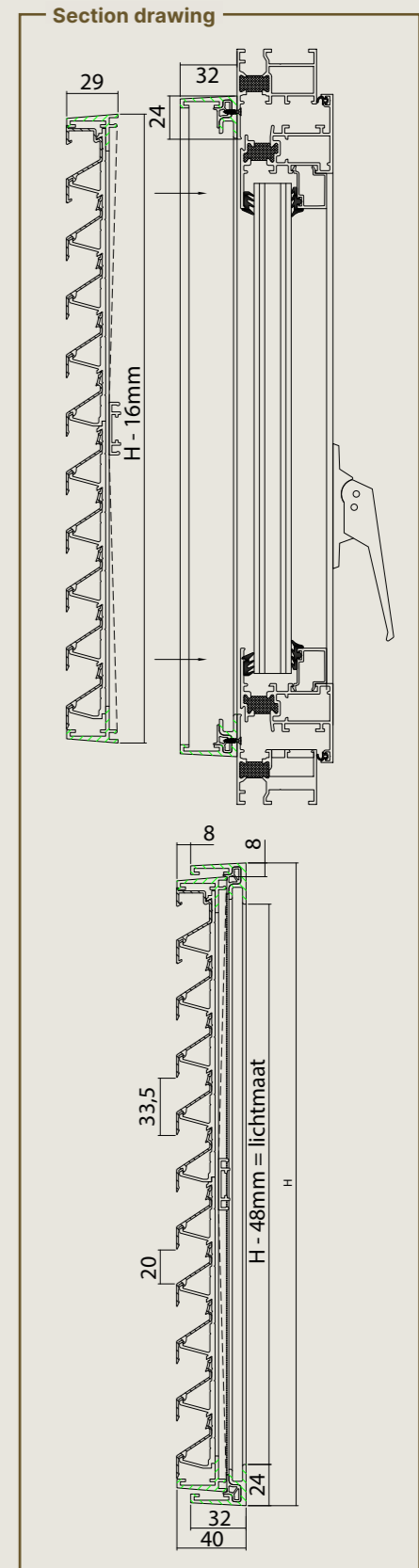

OUTDOOR
SURFACE MOUNTED

Available options

- Finish:** Anodised: layer thickness 25 microns / other colours / other textures (E1-E10)
Powder coating: pre-treatment in accordance with Seaside OX (pre-anodisation) / non-standard powders
- Other mesh types:** Mesh sizes 2.3 mm x 2.3 mm, 6 mm x 6 mm, 10 mm x 10 mm or 20 mm x 20 mm / Stainless steel grade AISI304 or AISI316 / No mesh

433/L

Aluminium surface-mounted industrial pressure relief louvre for large dimensions



Stock models			
Dimensions (W x H) mm	Natural colour anodised	flow rate at 10 Pa (m ³ /h)	flow rate at 20 Pa (m ³ /h)
328 × 328	17402	125.8	355.8
428 × 428	10470	246.2	696.4
528 × 528	10417	405	1145.5

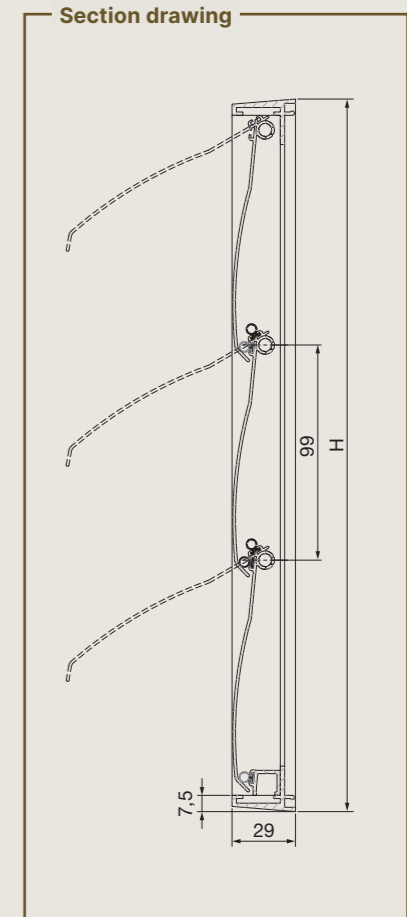

OUTDOOR
SURFACE MOUNTED

Material properties	Standard version	
Material	Aluminium, alloy EN AW-6063 T66	
Surface treatment	Anodisation (20 microns), chemically etched F1-E6 natural colour	Polyester powder coating (60-80 micron) Seaside quality A & Standard powders
Dimensions		
Blade pitch	99 mm	
Depth	29 mm	
Minimum dimensions (W x H)	300 × 328 mm	
Maximum dimensions	800 × 1.528 mm	
Preferred height	328 mm + (n x 100)	

Our louvres come in a variety of dimensions, all of which can be used across most applications. When using large sizes in high-stress environments, such as at great heights, it is advisable to additionally verify the stability of the louvres and their mounting.

Available options

- Finish:** Anodised: layer thickness 25 microns / other colours / other textures (E1-E10)
 Powder coating: pre-treatment in accordance with Seaside OX (pre-anodisation) / non-standard powders

433/S

Aluminium surface-mounted residential pressure relief louvre for small dimensions



Stock models							
Dimensions (W x H) mm	Natural colour anodised	Renson Standard White	STR 7016	STR 9005	RAL 8019	flow rate at 10 Pa (m³/h)	flow rate at 20 Pa (m³/h)
173 × 173	10113	9070	13450	17455	-	15.4	106.4
210 × 210	10114	9071	13452	10546	-	36.9	129.4
246 × 246	13454	13455	-	-	10115	50.45	219.05

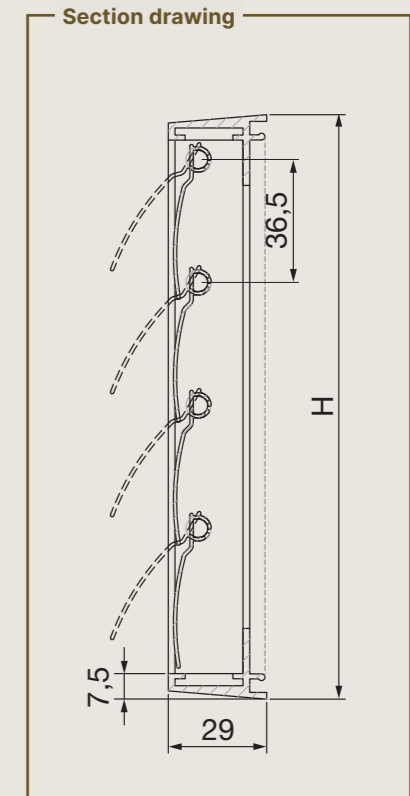

OUTDOOR
SURFACE MOUNTED

Material properties		Standard version	
Material	Aluminium, alloy EN AW-6063 T66		
Surface treatment	Anodisation (20 microns), chemically etched F1-E6 natural colour	Polyester powder coating (60-80 micron) Seaside quality A & Standard powders	
Dimensions			
Blade pitch	36.5 mm		
Depth	29 mm		

Available options

- Finish:** Anodised: layer thickness 25 microns / other colours / other textures (E1-E10)
 Powder coating: pre-treatment in accordance with Seaside OX (pre-anodisation) / non-standard powders

436

Flat aluminium surface-mounted louvre



Stock models

Dimensions (W x H) mm	Aluminium	Natural colour anodised	Renson Standard White	STR 7016	STR 9005	RAL 8019	flow rate at 2 Pa (m³/h)	flow rate at 10 Pa (m³/h)	flow rate at 20 Pa (m³/h)
150 × 150	16251	16252	-	8707	8329	10864	16	35.8	50.6
150 × 200	16253	-	16254	-	-	10865	21.9	49	69.3
200 × 100	8330	-	16255	8708	16256	10866	12	26.8	37.9
200 × 200	8331	-	8332	16257	8333	8710	22.1	49.4	69.9
200 × 250	16258	-	8334	16259	8712	16260	36.7	82.1	116.1
250 × 100	16261	-	10867	-	-	10868	18.5	41.4	58.5
250 × 250	16262	-	8713	-	-	10869	46.6	104.2	147.4
300 × 100	8335	-	8336	-	-	16263	20.2	45.2	63.9
300 × 300	10870	-	8338	8337	8714	8339	73.5	164.4	232.4
400 × 100	8715	-	10871	-	-	16265	28.8	64.4	91.1
400 × 400	16266	-	8716	-	-	8340	86.4	193.2	273.2
500 × 500	8343	-	10872	-	-	8344	125.9	281.5	398.1

Drawings

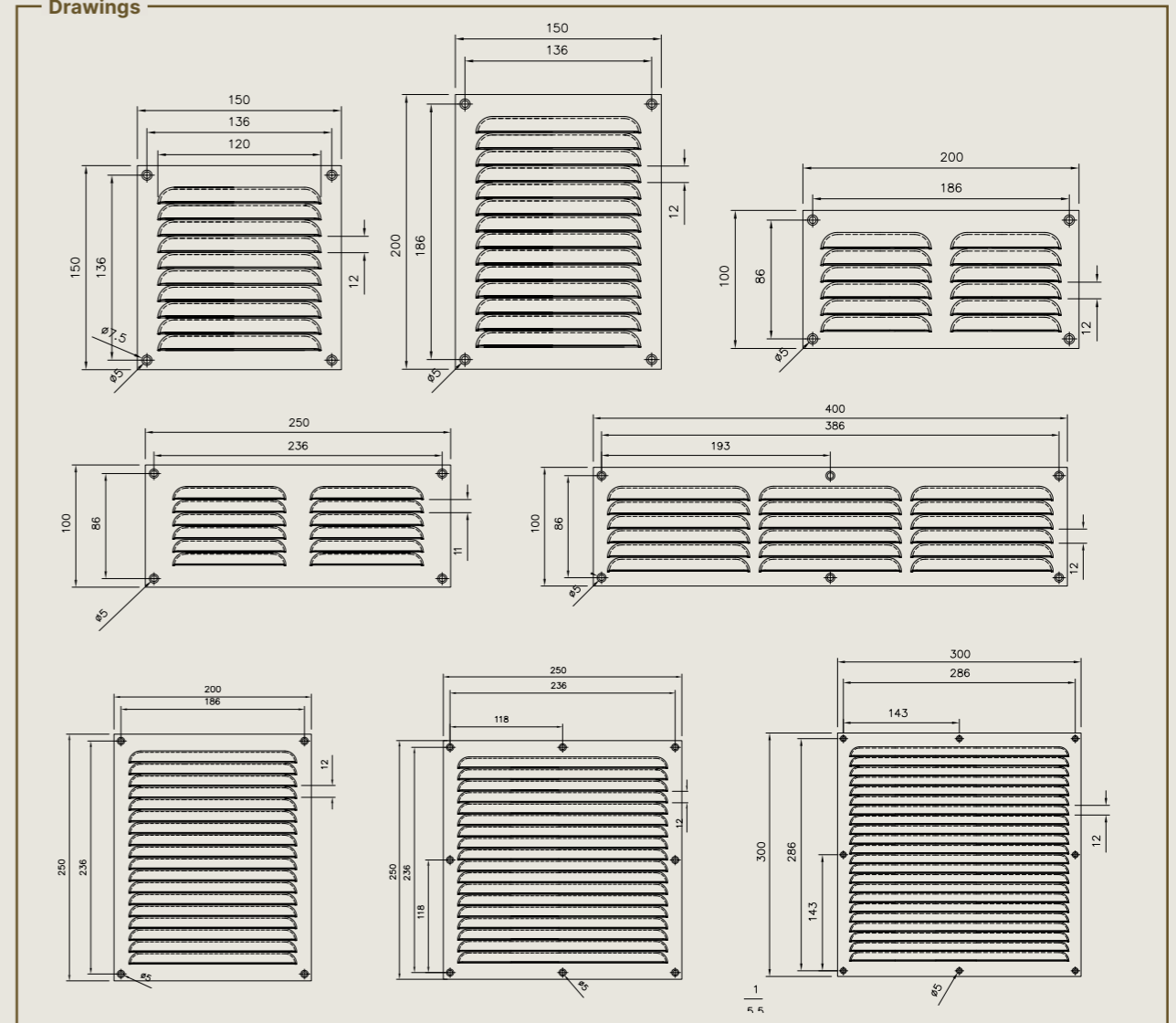

Available options

- Finish Non-standard powders

Material properties

Standard version

Material	Aluminium	
Surface treatment	Anodisation (20 microns), chemically etched F1-E6 natural colour	Polyester powder coating (60-80 micron) Seaside quality A & Standard powders

OUTDOOR
SURFACE MOUNTED

437

Aluminium surface-mounted louvre with frame



437 stock models

Dimensions (W x H) mm	Natural colour anodised	Renson Standard White	RAL 8019	STR 7016	STR 9005	flow rate at 2 Pa (m³/h)	flow rate at 10 Pa (m³/h)	flow rate at 20 Pa (m³/h)
155 x 155	9374	10890	16280	16279	8366	16	35.8	50.6
155 x 205	10891	16281	8729	-	-	21.9	49	69.3
205 x 105	9375	8730	-	-	-	12	26.8	37.9
205 x 205	10892	16283	8731	16282	9376	22.1	49.4	69.9
205 x 255	8732	16284	9377	-	-	36.7	82.1	116.1
255 x 105	16285	9378	16286	-	-	18.5	41.4	58.5
255 x 255	16287	16288	9483	-	-	46.6	104.2	147.4
305 x 105	8733	9484	9379	-	-	20.2	45.2	63.9
305 x 305	9381	10893	8735	-	-	73.5	164.4	232.4
405 x 105	9485	9382	8736	-	-	28.8	64.4	91.1
405 x 405	9383	10894	8737	-	-	86.4	193.2	273.2
505 x 505	8738	8739	9384	-	-	125.9	281.5	398.1

Drawings

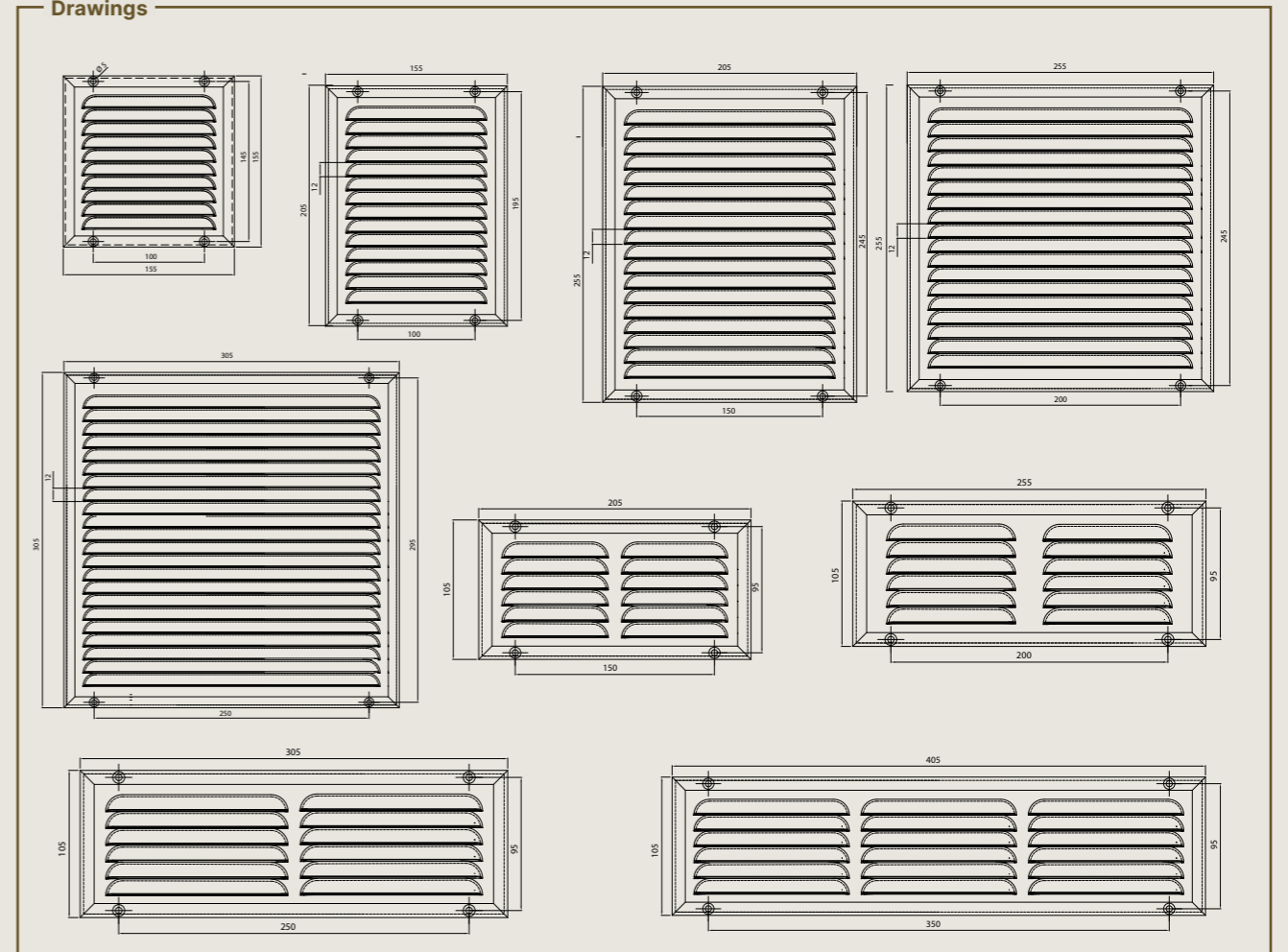

Material properties		Standard version
Material	Aluminium	
Surface treatment	Anodisation (20 microns), chemically etched F1-E6 natural colour	Polyester powder coating (60-80 micron) Seaside quality A & Standard powders

Available options

- Finish Non-standard powders

OUTDOOR
SURFACE MOUNTED

438 - 439

438: Flat stainless steel surface-mounted louvre

439: Aluminium surface-mounted louvre with border



438



439

Stock models

Dimensions (W x H) mm	Renson Standard white	RAL 8019	Stainless steel	flow rate at 2 Pa (m ³ /h)	flow rate at 10 Pa (m ³ /h)	flow rate at 20 Pa (m ³ /h)
Type 438 louvre						
150 × 150			19017	15.8	35.3	50
200 × 200			19018	21.3	47.6	67.4
250 × 100			19019	16.2	36.2	51.2
Type 439 louvre						
155 × 155	10591			15.9	35.6	50.3
195 × 195	17494	16217		-	-	-
246 × 195	10593	16220		31.4	70.2	99.3
215 × 150	8300	17495		20.3	45.4	64.2

Drawings - 438

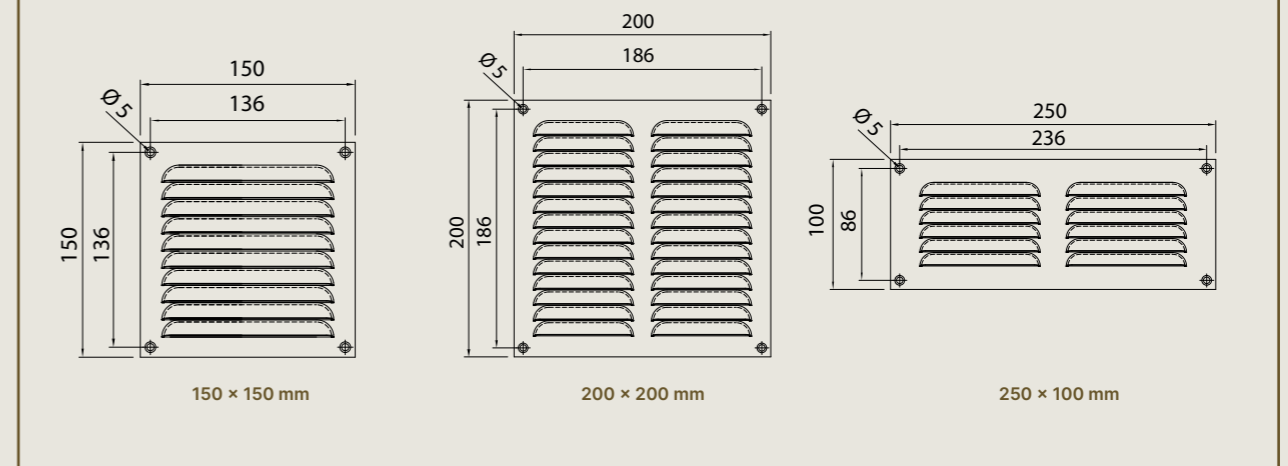

Tekeningen - 439

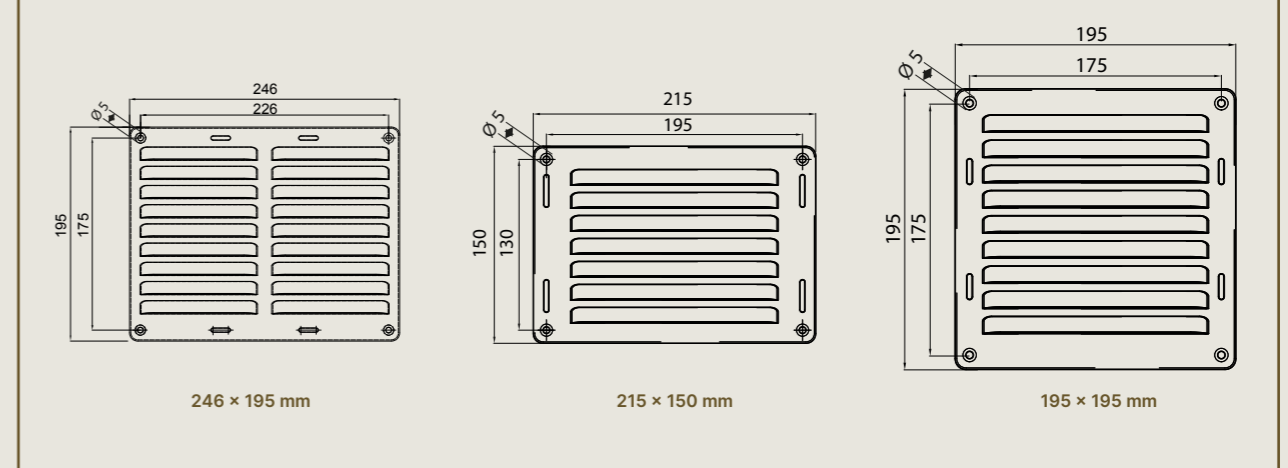

Material properties	438	439
Material	Stainless steel	Aluminium

443 - 633

443: Aluminium surface-mounted louvre with rain cap and pipe connection

633: Stainless steel surface-mounted residential pressure relief louvre with pipe connection



443



633

Stock models						
Diameter	White	Black	Stainless steel (polished)	Stainless steel (black)	Discharge flow rate at 10 Pa (m³/h)	Supply flow rate at 10 Pa (m³/h)
Type 443 louvre						
150 mm	17120	12013	-	-	220	134
180 mm	17801	12014	-	-	363	206
Type 633 louvre						
100 mm	-	-	9816	9817	5.9	-
125 mm	-	-	9818	9819	18	-
150 mm	-	-	10147	9820	13.9	-

Material properties	443	633
Material	Aluminium	Stainless steel
Surface treatment	Polyester powder coating (60-80 micron)	-

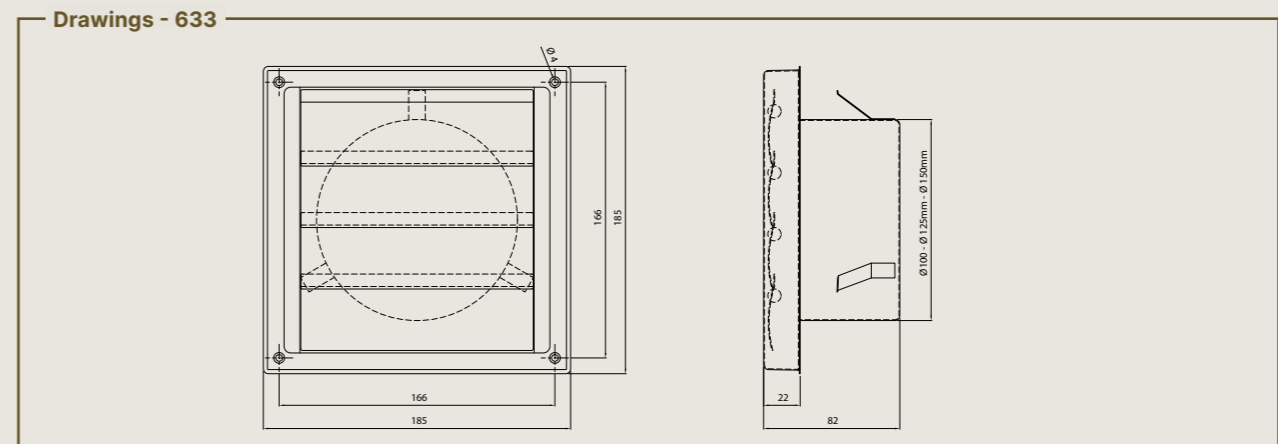
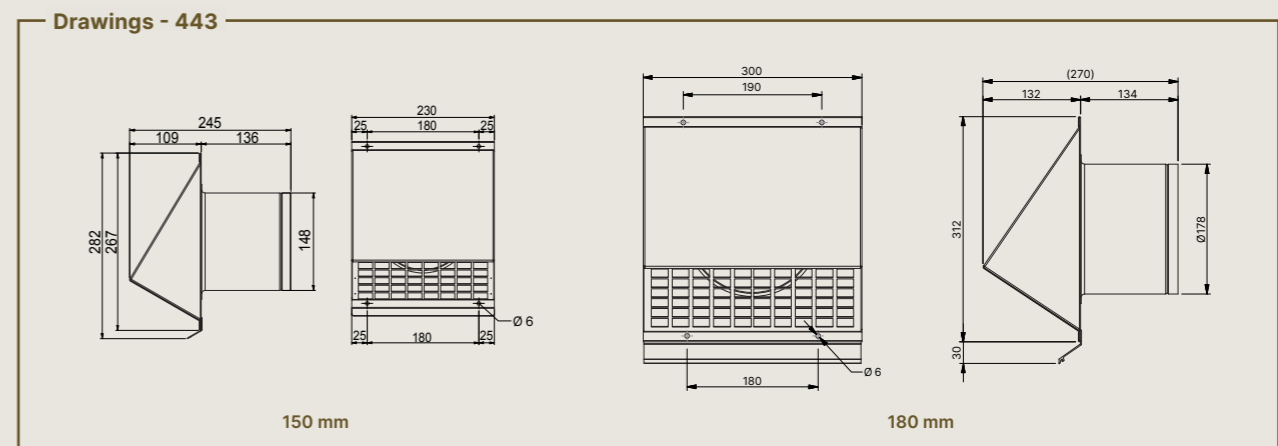

OUTDOOR
SURFACE MOUNTED

638 - 641

638: Stainless steel surface-mounted louvre with rain cap and pipe connection

641: Stainless steel surface-mounted residential pressure relief louvre with rain cap and pipe connection



638

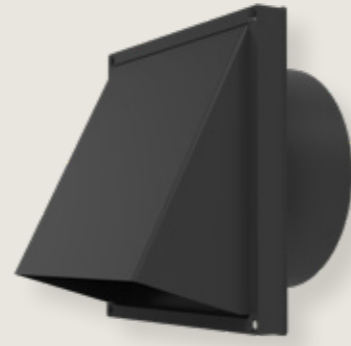

641

Stock models					
Diameter	Stainless steel (polished)	Stainless steel (black)	flow rate at 2 Pa (m³/h)	flow rate at 10 Pa (m³/h)	flow rate at 20 Pa (m³/h)
Type 638 louvre					
100 mm	17479	17757	19.8	44.3	62.6
125 mm	10148	17759	24.3	54.3	76.8
150 mm	17480	9341	31.1	69.5	98.3
Type 641 louvre					
100 mm	8346	10976	-	32.7	-
125 mm	8718	9343	-	53.4	-
150 mm	8347	9344	-	56.9	-

OUTDOOR
SURFACE MOUNTED

Drawings - 638

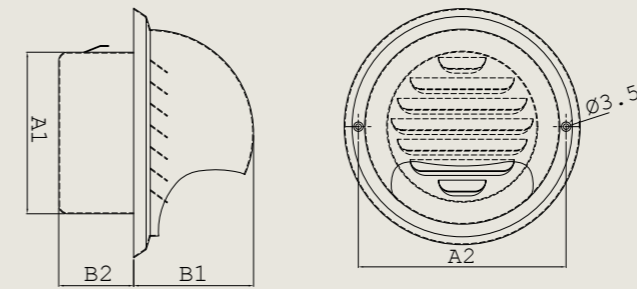

Diameter	100 mm	125 mm	150 mm
A	150	180	215
A1	95	120	145
A2	132	158	188
B1	80	100	120
B2	45	48.5	52.5

Drawings - 641

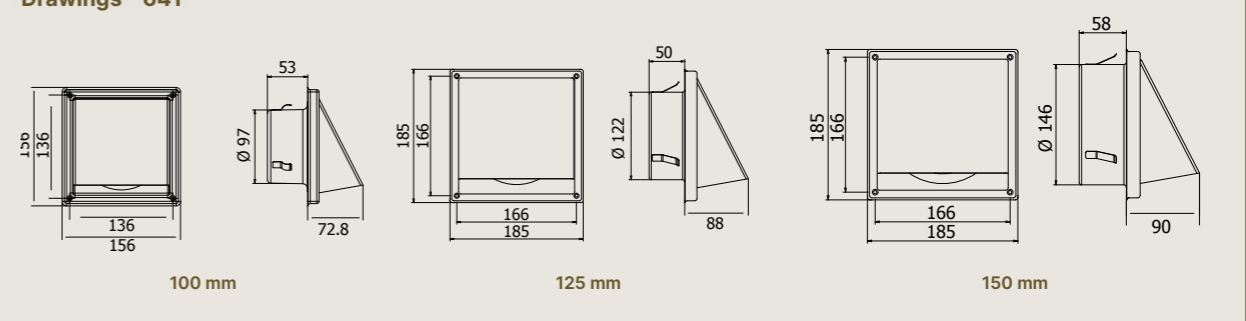

Material properties	638	641
Material	Stainless steel	

733 - 741 - 742

- 733:** UPVC surface-mounted residential pressure relief louvre
- 741:** UPVC surface-mounted residential pressure relief louvre with rain cap and pipe connection
- 742:** UPVC surface-mounted residential pressure relief louvre with pipe connection



733

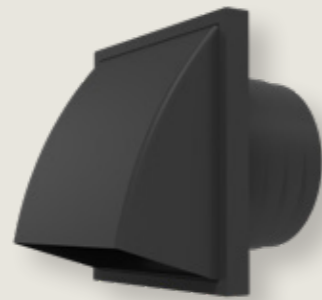

741



742

Stock models				
Dimensions (W x H) mm	Brown	White	Black	flow rate at 10 Pa (m ³ /h)
Type 733 louvre				
154 × 154	16270	10878	10877	45.5
187 × 187	8353	16271	8720	51.4
Type 741 louvre				
Diameter: 100-130	8355	16275	8354	64.2
Type 742 louvre				
Diameter: 100-130	8357	8356	10881	59.1

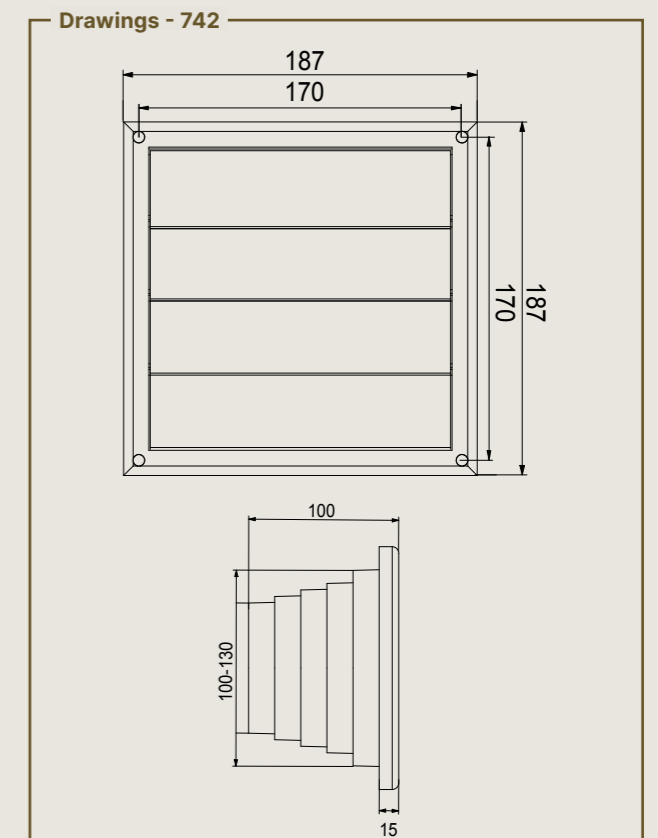
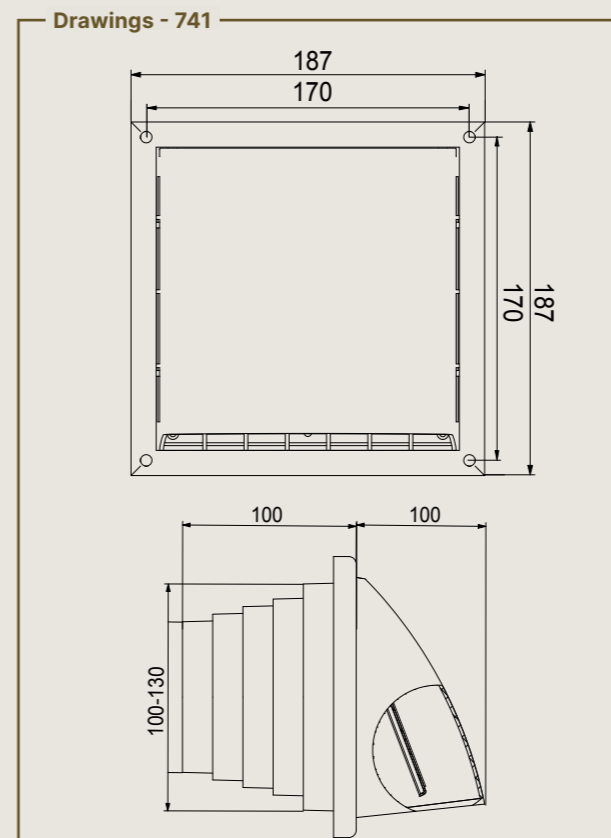
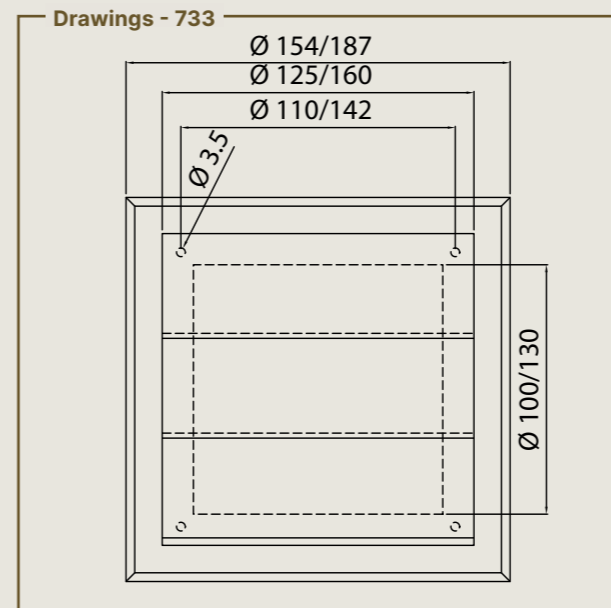

Material properties	733	741	742
Material		PVC	
Dimensions			
Blade pitch	40 mm	-	40 mm

OUTDOOR
SURFACE MOUNTED

ROOF TURRETS



OUTSIDE
ROOF TURRETS

440

Roof turret

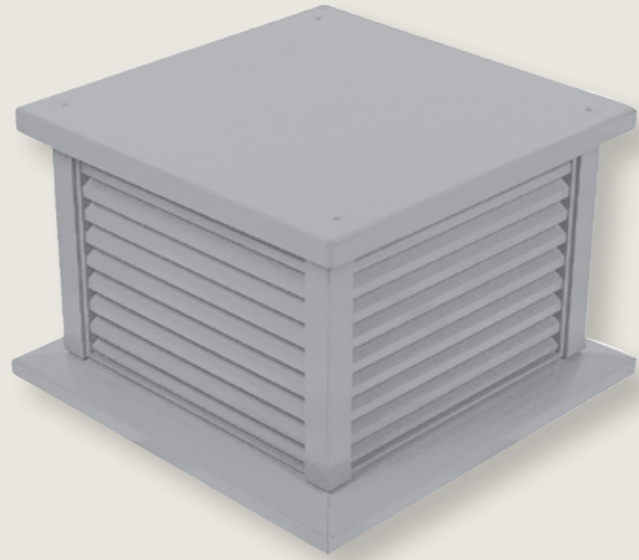

Material properties		Standard version	
Material	Aluminium, alloy EN AW-6063 T66		
Standard mesh type	Depends on turret type		
Surface treatment	Anodisation (20 microns), chemically etched F1-E6 natural colour	Polyester powder coating (60-80 micron) Seaside quality A & Standard powders	
Dimensions			
Minimum dimensions (L x H)	Depends on minimum dimensions of louvres used		
Maximum width	2000 mm		
Maximum length	4000 mm		
Maximum surface area	4 m ²		
Maximum height	2000 mm		
Larger roof turrets can be fitted with our Linius system			

Our louvres come in a variety of dimensions, all of which can be used across most applications. When using large sizes in high-stress environments, such as at great heights, it is advisable to additionally verify the stability of the louvres and their mounting.

Performance
Airflow rate
Depends on type of louvre selected

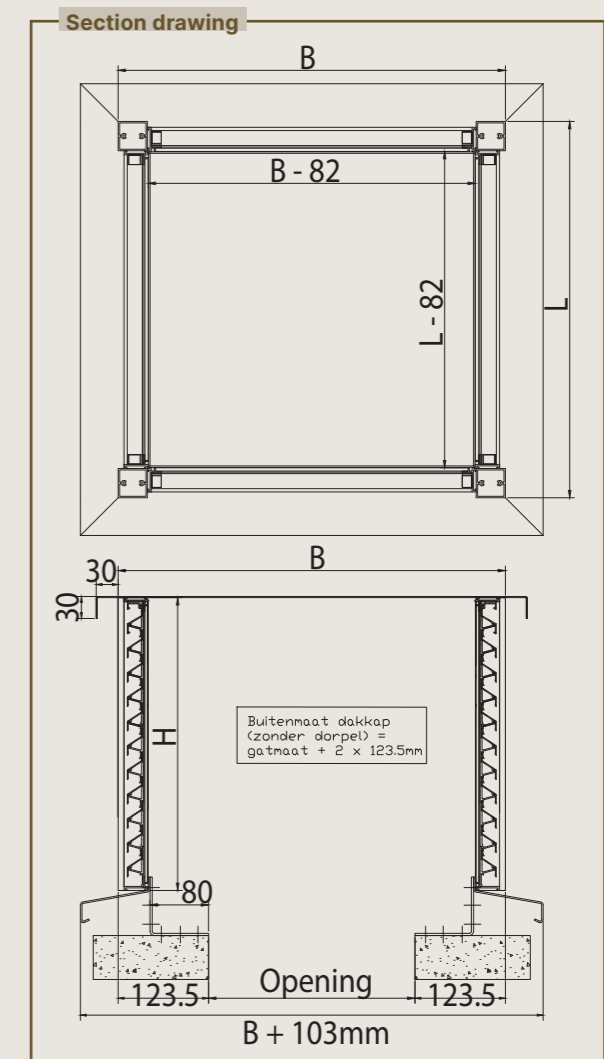

Type	Blade pitch
440/11 with Type 411 louvre	33 mm
440/21 with Type 421 louvre	50 mm
440/80 with Type 480 louvre	60 mm
440/81 with Type 481 louvre	50 mm

Available options

- **Roof plate with noise reduction**
- **Finish:** Anodised: layer thickness 25 microns / other colours / other textures (E1-E10)
Powder coating: pre-treatment in accordance with Seaside OX (pre-anodisation) / non-standard powders
- **Other mesh types:** Mesh sizes 2.3 mm x 2.3 mm, 6 mm x 6 mm, 10 mm x 10 mm or 20 mm x 20 mm / Stainless steel grade AISI304 or AISI316 / No mesh
- **Water channel**

WALL / CEILING LOUVRES FOR INSIDE APPLICATIONS



INSIDE
WALL/CEILING

381

Aluminium built-in ventilation strip

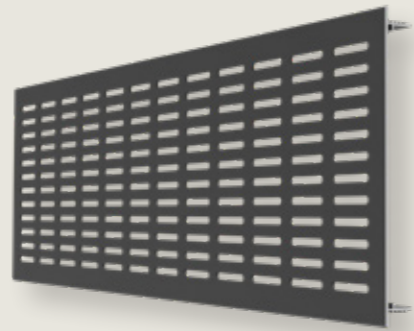

Stock models								
Dimensions (W x H) mm	Natural colour anodised	Renson Standard WHITE	RAL 8022	STR 9005	Airflow opening at cm ²	flow rate at 2 Pa (m ³ /h)	flow rate at 10 Pa (m ³ /h)	flow rate at 20 Pa (m ³ /h)
400 × 60	13922	9147	9147	-	44	17.0	38	53.8
500 × 60	9149	17415	9148	-	59	22.8	51	72.1
2000 × 60	17416	10485	-	-	244	94.4	211.1	298.5
300 × 80	9154	17423	9155	-	43	17.6	39.4	55.7
400 × 80	13929	9156	13930	17424	56	22.4	50.1	70.8
500 × 80	9157	17425	9158	10489	74	29.6	66.2	93.6
600 × 80	10490	13931	-	-	87	33.6	75.1	106.3
1000 × 80	9159	10491	-	-	149	57.6	128.8	182.1
2000 × 80	9160	-	-	-	305	117.9	263.6	372.8
300 × 100	10492	13932	-	-	61	23.6	52.8	74.6
400 × 100	13933	9161	9162	-	78	30.2	67.5	92.5
500 × 100	10493	13934	10494	-	104	40.2	89.9	127.1
600 × 100	17426	10495	10496	-	122	47.2	105.5	149.3
1000 × 100	9163	10497	-	-	209	80.8	180.7	255.5
2000 × 100	17427	13935	-	-	427	165.1	369.2	522.1
500 × 130	17428	10498	-	-	149	57.6	128.8	182.1
1000 × 130	10499	9164	-	-	298	115.2	257.6	364.3
2000 × 130	13936	17429	-	-	610	235.9	527.5	746
500 × 150	9165	17430	-	-	179	69.2	154.7	218.8
2000 × 150	9166	10500	-	-	732	283.1	633	895.2

INSIDE WALL/CEILING

Material properties	Standard version
Material	Aluminium
Surface treatment	Anodised (20 microns), chemically etched F1-E6 natural colour
Dimensions	
Recess depth	13 mm

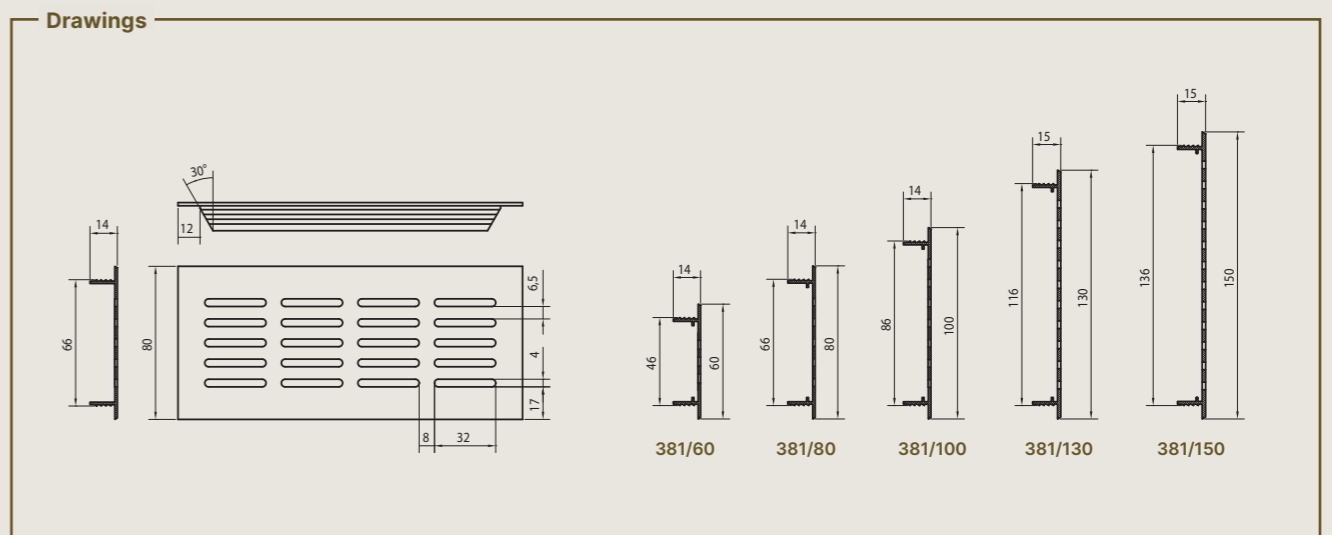

Available options

- **Finish:** Powder coating: pre-treatment in accordance with Seaside OX (pre-anodisation) / non-standard powders

441

Aluminium adjustable interior louvre with frame



Performance		
Airflow rate		
Physical free area		25%
Air supply	Resistance factor K	30.1
	Flow coefficient C	0.182
	Airflow rating	4
Air extraction	Resistance factor K	30.1
	Flow coefficient C	0.182
	Airflow rating	4

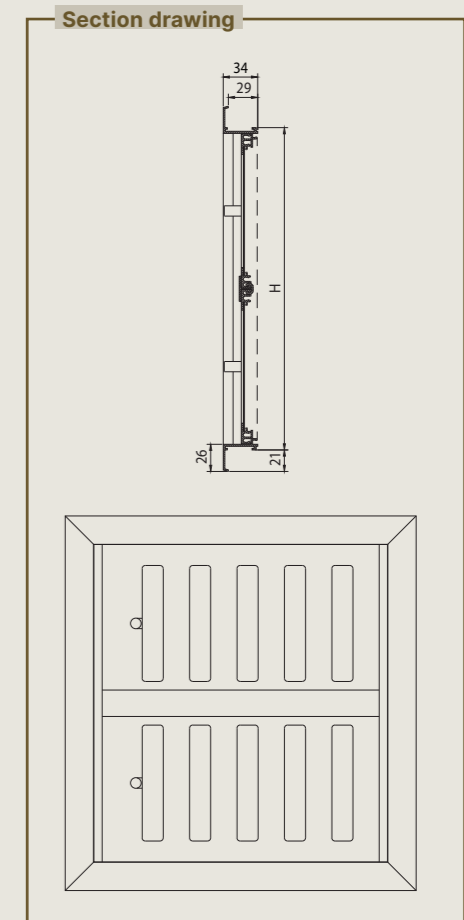

Material properties		Standard version	
Material	Aluminium, alloy EN AW-6063 T66		
Standard mesh type	Stainless steel 304 - 2.3 × 2.3 mm		
Surface treatment	Anodisation (20 microns), chemically etched F1-E6 natural colour	Polyester powder coating (60-80 micron) Seaside quality A & Standard powders	
Wall bracket type	no. 418 (included)		
Control	Slider or rotary knob depending on dimensions		
Dimensions			
Recess depth	29 mm		
Flange	21 mm		
Minimum dimensions (W x H)	142 × 142 mm		
Maximum width	3000 mm		
Maximum height	3000 mm		
Maximum louvre surface area	3.3 m ²		
If H > W, sliders are placed vertically			

Available options

- **Mounting method:** Long dowels no. 418L / Clip springs no. 419 / Screw holes in flange frame
- **Control:** Cord / Rod / 230V or 24V linear actuator / 230V or 24V fire damper actuator
- **Finish:** Powder coating: non-standard powders

INSIDE
WALL/CEILING

464/1 - INCENDO

Fire-resistant interior louvre EI 60



Performance		
Airflow rate		
Physical free area		51%
Visual free area		61%
Air supply	Resistance factor K	10.3
	Flow coefficient C	0.312
	Airflow rating	2
Air extraction	Resistance factor K	10.3
	Flow coefficient C	0.312
	Airflow rating	2
IP rating		
IP2XD		
Fire rating		
Solid (concrete) walls (100 mm)		EI60/EW90 (ve i↔0)
Solid (concrete) floors (100 mm)		EI60 (ho i↔0)
Flexible wall (metal stud plasterboard 100 mm)		EI60 (ve i↔0)

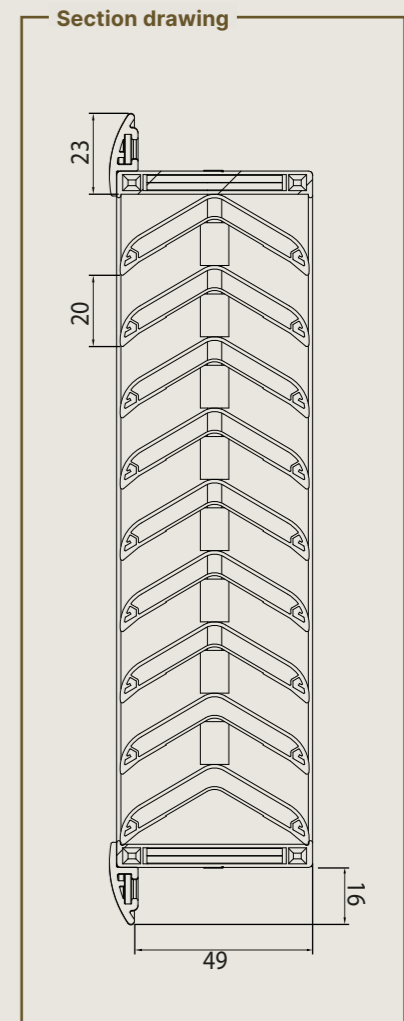

Operation: In case of fire, ventilation is cut off by the intumescence of the blades (starting at 100 °C). The louvre acts as a static fire damper for 60 minutes.
Not water resistant

Material properties	Standard version
Material	Polystyrene-Palusol
Available colours	RAL 9022 (light grey), RAL 9016 (white) and RAL 7024 (dark grey)
Dimensions	
Blade pitch	20 mm
Recess depth	49 mm
Flange	16 mm
Preferred width	100 mm + (n x 50)
Preferred height	100 mm + (n x 50)
Minimum dimensions (W x H)	100 × 100 mm
Maximum width	800 mm
Maximum height	400 mm
Maximum louvre surface area	0.32 m ²

INSIDE
WALL/CEILING

467

Fire-resistant interior louvre EI 120

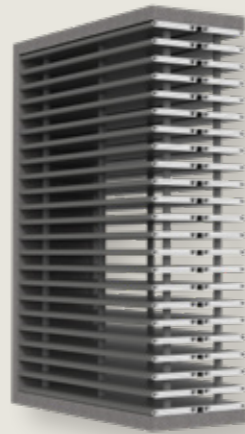

Operation: In case of fire, ventilation is cut off by the intumescence of the blades (starting at 100 °C). The louvre acts as a static fire damper for 60 minutes.
Not water resistant

Material properties	Standard version
Material	Polystyrene-Palusol
Colour	Grey
Dimensions	
Blade pitch	18 mm
Recess depth	100 mm
Minimum dimensions (W x H)	150 x 100 mm
Maximum width	1200 mm
Maximum height	800 mm
<ul style="list-style-type: none"> Width and height must always be a multiple of 100 mm Dimensions supplied are always 5 mm smaller than dimensions ordered Required wall opening depending on installation material: see sectional drawings 	
Maximum louvre surface area	0.96 m ²

Performance		
Airflow rate		
Physical free area		67%
Visual free area		67%
Air supply	Resistance factor K	4.2
	Flow coefficient C	0.490
	Airflow rating	1
Air extraction	Resistance factor K	4.1
	Flow coefficient C	0.496
	Airflow rating	1
Fire rating		
Solid (concrete) walls (100 mm)		EI120 (ve i↔0)

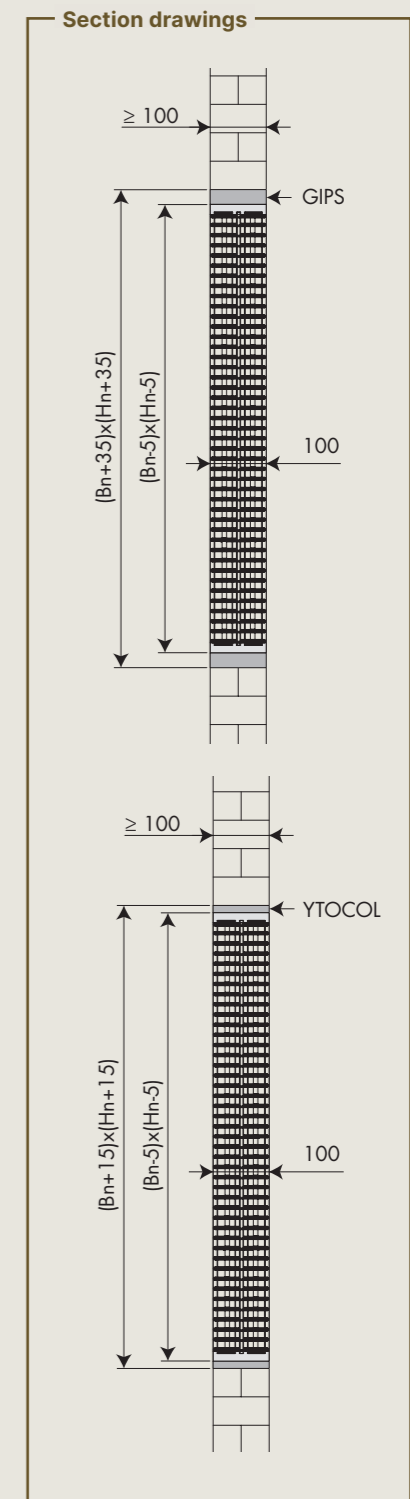

INSIDE
WALL/CEILING

468AK/1

Aluminium noise-reducing door louvre, Rw 8dB

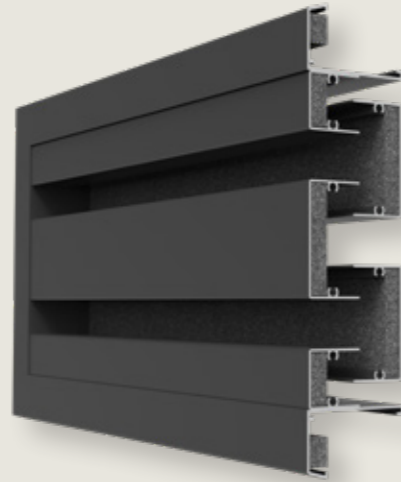

Material properties	Standard version
Material	Aluminium, alloy EN AW-6063 T66
Surface treatment	Anodised (20 microns), chemically etched F1-E6 natural colour
Mounting	Mounting screws included
Dimensions	
Blade pitch	85 mm
Recess depth	60 mm
Flange	30 mm
Minimum dimensions (W x H)	200 x 180 mm
Maximum width	800 mm
Maximum height	775 mm
Maximum louvre surface area	0.62 m ²
Available heights	180 mm + (n x 85)

Performance		
Airflow rate		
Physical free area		29%
Visual free area		29%
Air supply	Resistance factor K	87.3
	Flow coefficient C	0.107
	Airflow rating	4
Air extraction	Resistance factor K	89.0
	Flow coefficient C	0.106
	Airflow rating	4
Noise reduction dB		
R _w (C _i ; C _e)		8 (-1; -2)
f in Hz		R in dB
63		2.5
125		6.2
250		5.1
500		4.6
1000		5.1
2000		12.5
4000		18.5

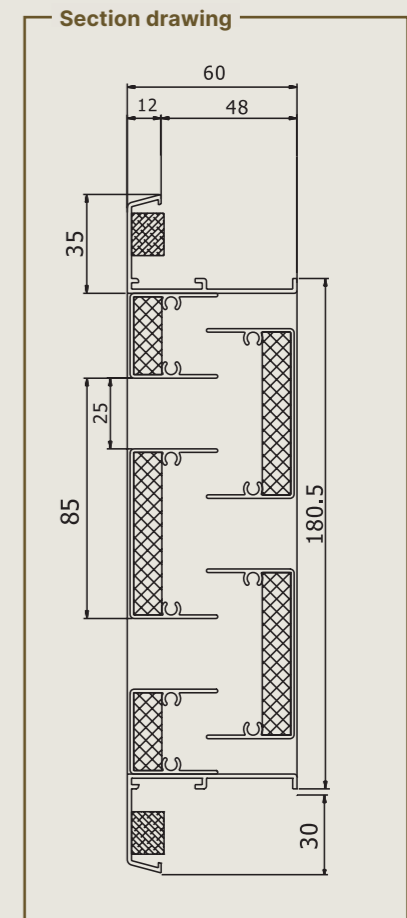

INSIDE
WALL/CEILING

Available options

- **Finish:** Anodised: layer thickness 25 microns / other colours / other textures (E1-E10)

636 - 736

636: Stainless steel adjustable ventilation valve

736: UPVC adjustable ventilation valve



636



736

Stock models						
Dimensions (W x H) mm	Stainless steel (polished)	White	Black	flow rate at 2 Pa (m³/h)	flow rate at 10 Pa (m³/h)	flow rate at 20 Pa (m³/h)
Type 636 louvre						
Diameter: 100	8717	-	-	19.1	42.7	60.4
Diameter: 125	8345	-	-	38.5	86.1	121.7
Diameter: 150	10873	-	-	54.4	121.6	172
Type 736 louvre						
80 mm	-	16272	-	15.8	35.3	50
100 mm	-	10880	8721	16.9	37.8	53.4
125 mm	-	16273	8722	22	49.2	69.6
150 mm	-	8723	-	37	82.7	117
200 mm	-	16274	-	47.9	107.1	151.5

Drawings - 636

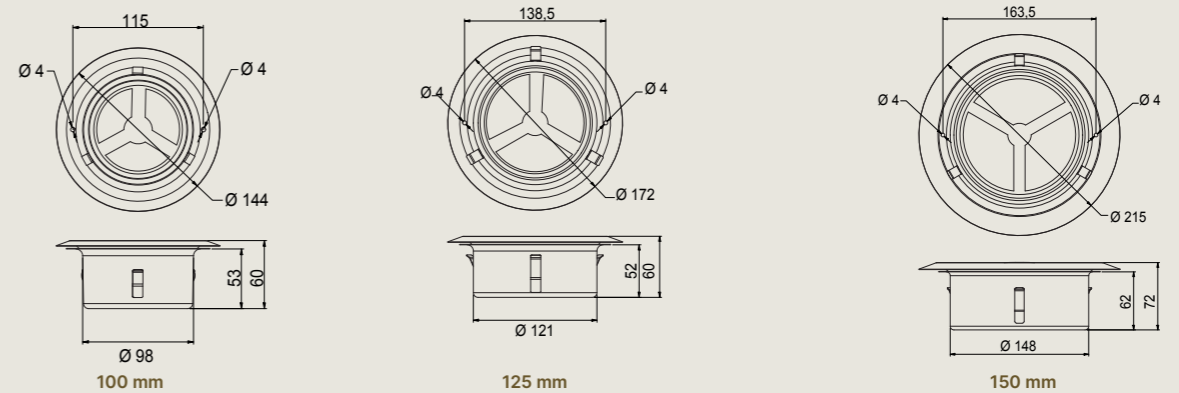

Drawings - 736

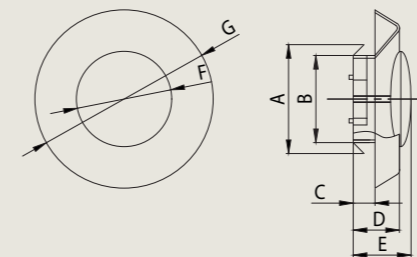

Diameter	80 mm	100 mm	125 mm	150 mm	200 mm
A	Ø 80	Ø 130	Ø 154	Ø 180	Ø 234
B	Ø 64	Ø 84	Ø 104	Ø 124	Ø 180
C	12	26	20	30	33
D	34	44	40	50	53
E	Max 43	Max 47	Max 55	Max 95	Max 95
F	Ø 70	Ø 90	Ø 110	Ø 130	Ø 180
G	Ø 131	Ø 148	Ø 170	Ø 200	Ø 240

Material properties	636	736
Material	Stainless steel	PVC

732 - 735

732: UPVC adjustable interior louvre

735: Round UPVC adjustable interior louvre



732



735

Stock models						
Diameter	White	Black	Brown	flow rate at 2 Pa (m³/h)	flow rate at 10 Pa (m³/h)	flow rate at 20 Pa (m³/h)
Type 732 louvre						
154 × 154	8348	10874	8349	15.6	34.9	49.3
187 × 187	8351	8350	8352	22.1	49.4	69.9
250 × 250	10875	-	10876	33.4	74.7	105.6
Type 735 louvre						
Diameter: varies	10879	-	-	19.8	44.3	62.6
100 mm	10880	8721	-	16.9	37.8	53.4
125 mm	16273	8722	-	22	49.2	69.6
150 mm	8723	-	-	37	82.7	117
200 mm	16274	-	-	47.9	107.1	151.5

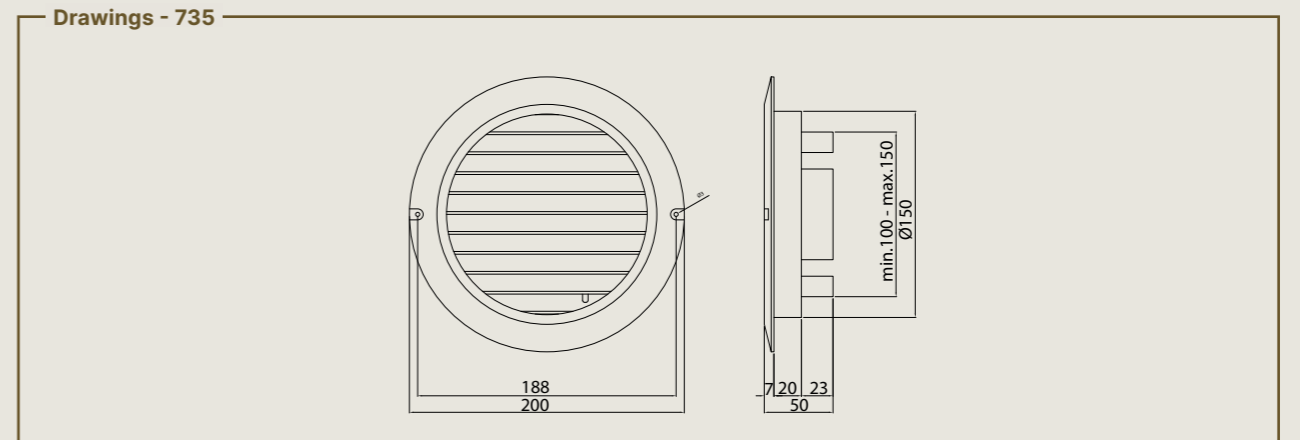
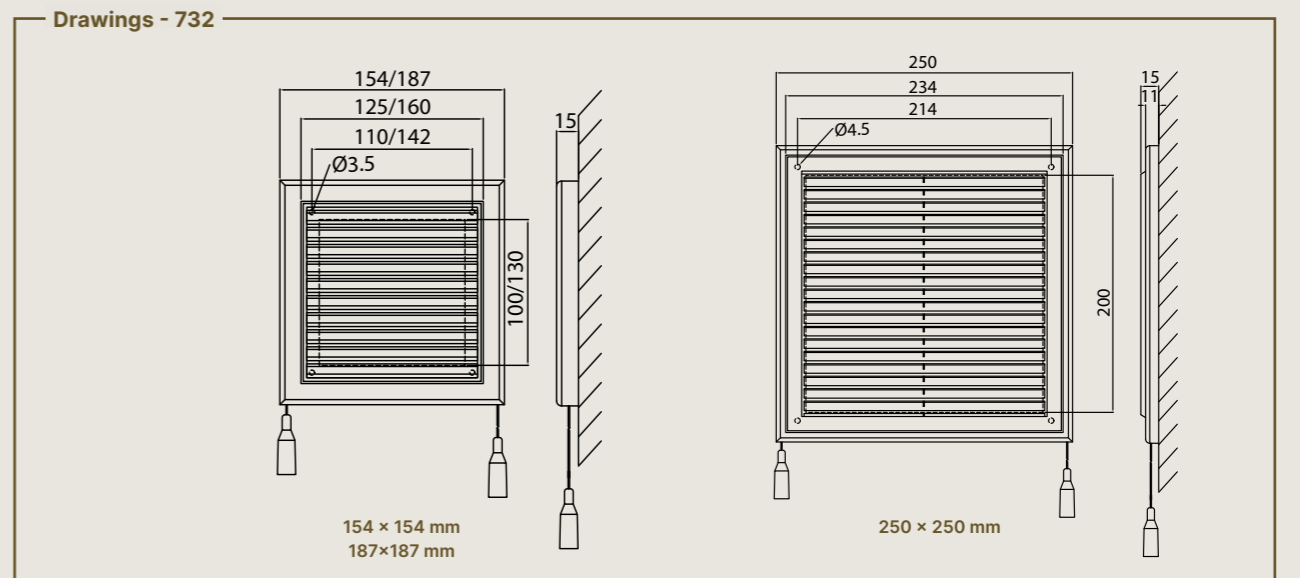

Material properties	732	735
Material	PVC	
Dimensions		
Blade pitch	12 mm	14 mm
Recess depth	-	43 mm
Depth	15 mm	-

INSIDE WALL/CEILING

4032 - 4037

4032: Aluminium adjustable interior louvre

4037: Aluminium adjustable interior louvre

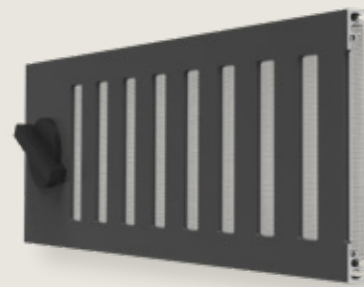

4032



4037

Material properties	4032	4037
Material	Aluminium, alloy EN AW-6063 T66	
Standard mesh type	Stainless steel 304 - 2.3 × 2.3 mm	
Surface treatment	Anodised (20 microns), chemically etched F1-E6 natural colour	-
Control	Slider or rotary knob depending on dimensions	Rotary knob
Dimensions		
Depth	10 mm	8 mm
Minimum dimensions (W x H)	100 × 100 mm	-
Maximum width	3000 mm	-
Maximum height	3000 mm	-
Maximum surface area	4.5 m ²	-

If H > W, sliders are placed vertically

Stock models							
Dimensions (W x H) mm	Natural colour anodised	Renson Standard WHITE	RAL 8019	Airflow opening in cm ²	flow rate at 2 Pa (m ³ /h)	flow rate at 10 Pa (m ³ /h)	flow rate at 20 Pa (m ³ /h)
Type 4032 louvre							
175 × 150	9128	11967	-	49	22.1	49.4	69.9
240 × 200	11968	10458	-	113	51.0	114	161.3
Type 4037 louvre							
155 × 155	8341	8342	16267	-	27	60.4	85.4

Type 4037 louvre Not available in custom dimensions; stock product only

Drawings - 4032

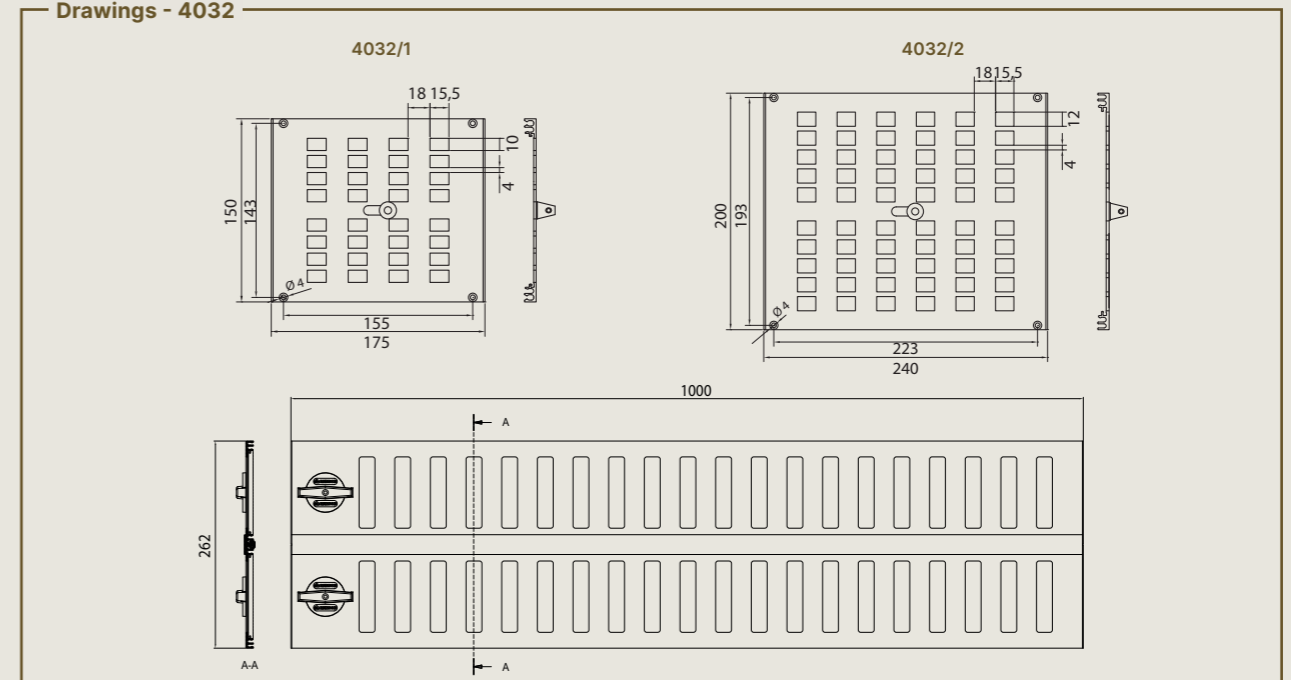

Available options - 4032

- **Control:** Cord / Rod / 230V or 24V linear actuator / 230V or 24V fire damper actuator
- **Finish:** Powder coating: non-standard powders

Drawing - 4037

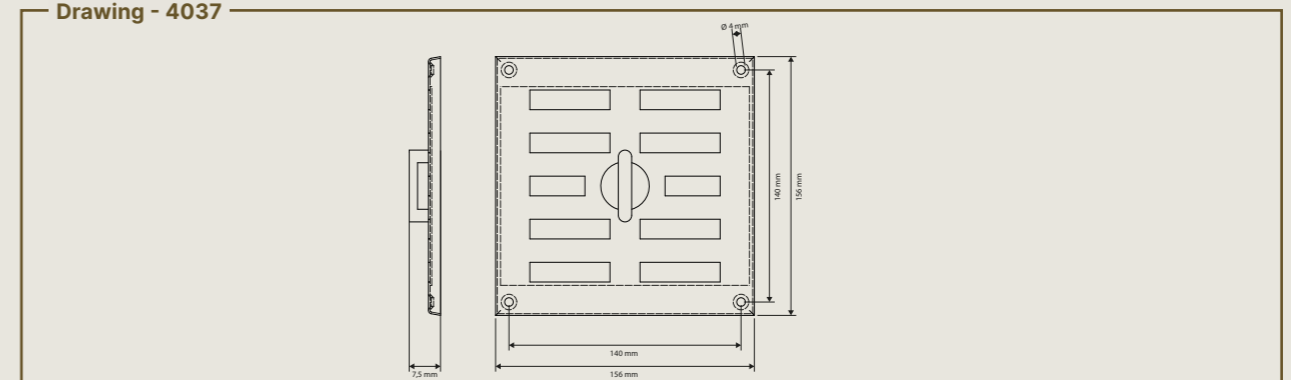

AEROO

Ventilation valve with pipe connection



Round



Square

Performance								
SUPPLY Without Air Blocker	25 m³/h		50 m³/h		75 m³/h		90 m³/h	
	Pressure drop Pa	Lw(A) dB(A)	Pressure drop Pa	Lw(A) dB(A)	Pressure drop Pa	Lw(A) dB(A)	Pressure drop Pa	Lw(A) dB(A)
100% open	1	<10.0	5	<10.0	9	16.5	12	21.0
62% open	2	<10.0	8	<10.0	17	19.0	23	25.0
32% open	4	<10.0	14	<10.0	30	19.0	43	25.5
20% open	12	<10.0	43	15.5	90	33.0	-	-

SUPPLY With Air Blocker	25 m³/h		50 m³/h		60 m³/h	
	Pressure drop Pa	Lw(A) dB(A)	Pressure drop Pa	Lw(A) dB(A)	Pressure drop Pa	Lw(A) dB(A)
100% open	4	<10.0	15	19.0	20	24.0
62% open	6	<10.0	22	21.5	30	27.0
32% open	9	<10.0	33	24.5	47	30.0

EXTRACTION	25 m³/h		50 m³/h		75 m³/h		100 m³/h	
	Pressure drop Pa	Lw(A) dB(A)	Pressure drop Pa	Lw(A) dB(A)	Pressure drop Pa	Lw(A) dB(A)	Pressure drop Pa	Lw(A) dB(A)
100% open	1	<10.0	6	<10.0	14	16.0	25	26.5
62% open	3	<10.0	11	<10.0	24	24.5	40	33.5
32% open	5	<10.0	18	15	41	29.5	-	-
20% open	14	<10.0	50	28.5	-	-	-	-

Stock models			
Aeroo	Dimensions (W x H) mm	White	Black
Round	Diameter: 125	17147	17831
Square	125 × 125 mm	17148	17832

See the full technical data sheets here



! Did you know that the air blocker allows you to direct the airflow exactly as required to prevent dirt from building up in the corners?

Material properties	Round	Square
Material	ASA UPVC	
Colour	RAL 9005 / 9010	
Mounting	Self-clamping rubber in both Easyflex and Spiro tube 125 mm	
Dimensions		
Diameter (W x H)	Diameter: 170 mm	170 × 170 mm
Height	33 mm	

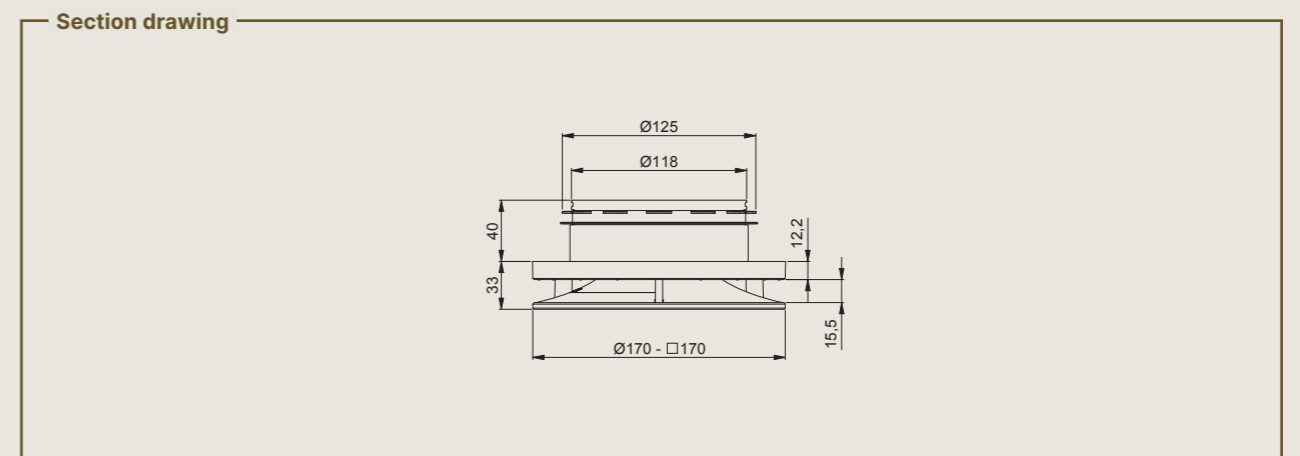

DESIGN EXTRACTION LOUVRES

Design aluminium interior louvre



Puro



Square



Artist



Aqua

Performance												
	Louvre base Ø 80 mm + Design louvre Installed on pipe diameter 82 mm						Louvre base Ø 125 mm + Design louvre Installed on pipe diameter 127 mm					
	Non-adjustable version		Adjustable version				Non-adjustable version		Adjustable version			
	Open		Open		Closed		Open		Open		Closed	
	Qnom (m³/h)	ΔP(Pa)	Qnom (m³/h)	ΔP(Pa)	Qnom (m³/h)	ΔP(Pa)	Qnom (m³/h)	ΔP(Pa)	Qnom (m³/h)	ΔP(Pa)	Qnom (m³/h)	ΔP(Pa)
PURO	19.1	2	17.5	2	13.8	100	46.9	2	44.9	2	27.1	100
	75	30.9	75	36.3	75	1661	75	5.1	75	5.6	75	462.1
	50	13.7	50	16.2	50	847	50	2.3	50	2.5	50	250.9
	25	3.4	25	4.1	25	267.8	25	0.6	25	0.6	25	88.3
SQUARE	20.2	2	18.5	2	13.3	100	48.5	2	46.7	2	26.2	100
	75	29.1	75	33.9	75	2320.3	75	4.8	75	5.1	75	548.2
	50	12.7	50	15	50	1110.5	50	2.1	50	2.3	50	284.3
	25	3.1	25	3.7	25	315	25	0.5	25	0.6	25	92.5
ARTIST	18.5	2	17.2	2	13.3	100	43.6	2	41.9	2	25.8	100
	75	33.8	75	39.4	75	1962.4	75	6	75	6.4	75	474.6
	50	14.9	50	17.4	50	976.3	50	2.6	50	2.9	50	262.5
	25	3.7	25	4.3	25	296	25	0.6	25	0.7	25	95.4
AQUA	17.7	2	16.1	2	13.7	100	45.4	2	43.8	2	26.8	100
	75	37.7	75	44.9	75	1768.9	75	5.4	75	5.8	75	455.3
	50	16.6	50	19.8	50	892.3	50	2.4	50	2.6	50	250.5
	25	4.1	25	4.9	25	277	25	0.6	25	0.7	25	90.2

Stock models		
Type	Dimensions mm	White
Puro	Diameter: 80	11722
	Diameter: 125	10937
Square	Diameter: 80	9530
Artist	Diameter: 80	11724
	Diameter: 125	9531
Aqua	Diameter: 80	9297
	Diameter: 125	11723

Material properties	Diameter: 80	Diameter: 125
Material	Aluminium	
Colour	RAL 9010	
Paintable	✓	
Dimensions		
Base (W x H)	134 × 134 mm	174 × 174 mm
Height	11 mm	

XD

Aluminium adjustable design ventilation valve

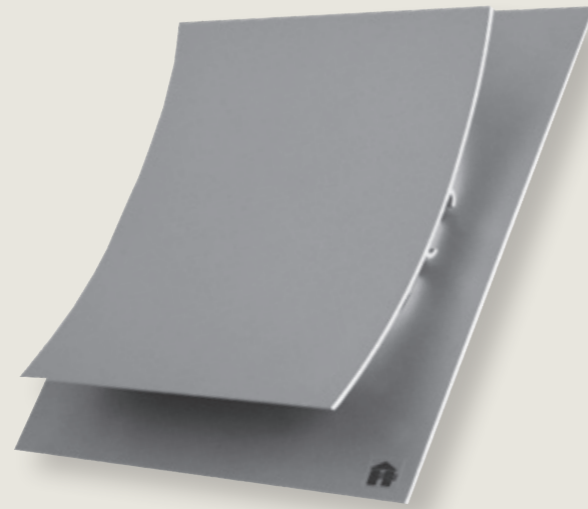

Performance		
Airflow rate	XD 2	XD 3
Position 1	39.2 m ³ /h at 2 Pa	63.0 m ³ /h at 2 Pa
Position 2	50.4 m ³ /h at 2 Pa continuously adjustable in between	87.1 m ³ /h at 2 Pa continuously adjustable in between

Stock models		
Type	Dimensions mm	Matte 9010
XD2	188 × 188 mm	29650
XD3	233 × 233 mm	29651

Material properties	XD 2	XD 3
Material	Aluminium	
Colour	RAL 9006 / Renson standard white	
Dimensions		
Base (W x H)	188 × 188 mm	233 × 233 mm
Depth	79 mm (closed)	
Extraction channel diameter	100 mm, 140 mm (max. ø 160 mm)	140 mm, 170 mm (max. ø 200 mm)

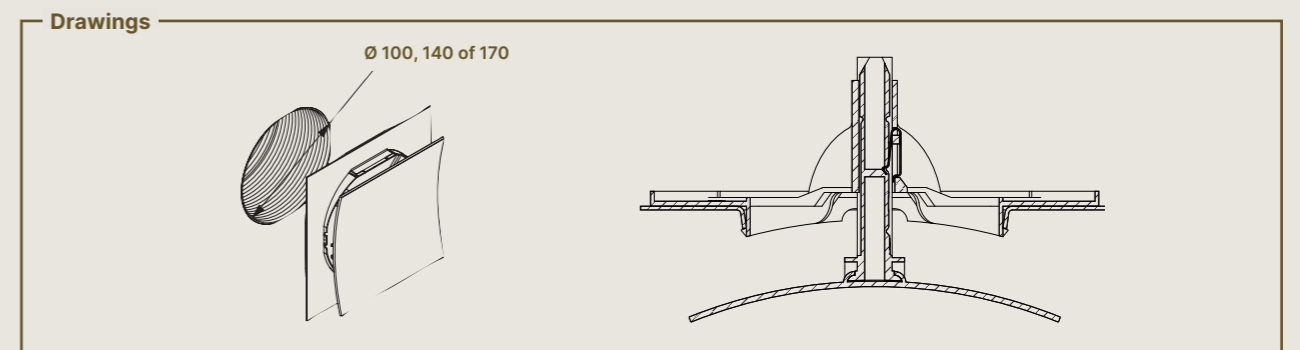

DOOR LOUVRES FOR INSIDE APPLICATIONS



461

Aluminium non-see-through door louvre with high air flow for door panels between 30 and 80 mm thick.

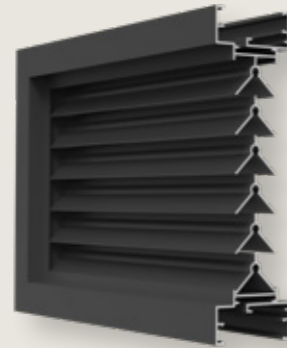

Material properties	Standard version
Material	Aluminium, alloy EN AW-6063 T66
Surface treatment	Anodised (20 microns), chemically etched F1-E6 natural colour
Wall bracket type	Mounting screws included
Dimensions	
Blade pitch	20 mm
Flange	15 mm
Door thickness	30 - 54 mm
Minimum dimensions (W x H)	200 mm x 76 mm
Maximum width	800 mm
Maximum height	1200 mm
Maximum louvre surface area	0.96 m ²

Performance		
Airflow rate		
Physical free area		39%
Visual free area		93%
Air supply	Resistance factor K	34.6
	Flow coefficient C	0.170
	Airflow rating	4
Air extraction	Resistance factor K	34.6
	Flow coefficient C	0.170
	Airflow rating	4

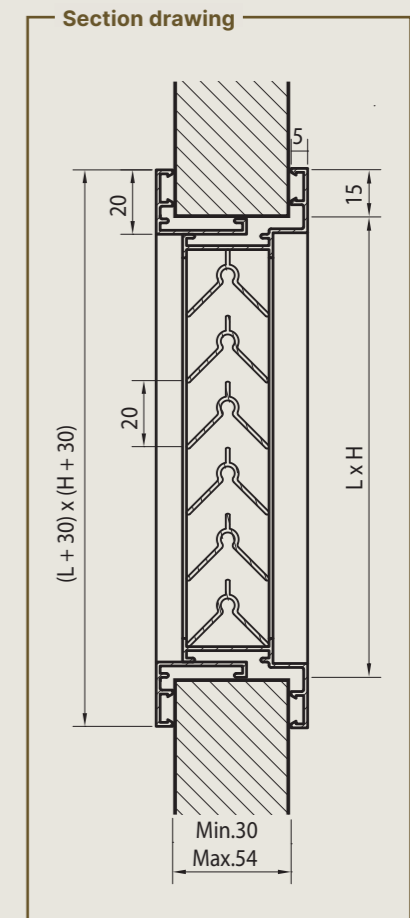

Stock models						
Dimensions (W x H) mm	Natural colour anodised	Renson Standard WHITE	RAL8019	flow rate at 2 Pa (m ³ /h)	flow rate at 10 Pa (m ³ /h)	flow rate at 20 Pa (m ³ /h)
200 × 100	17369			19.3	43.2	61
400 × 200	9093	9139	17404	83.8	187.4	265
400 × 300	17370			127.9	286	404.5
500 × 300	9094			160.7	359.3	508.2
600 × 400	11933			260.1	581.6	822.5
425 × 76	17359	9082	11923	31.0	69.3	98

Available options	
• Finish:	Anodised: layer thickness 25 microns / other colours / other textures (E1-E10)
• Counterframe for panel thicknesses between 55 mm and 80 mm	
• Closable	
• Control:	Sliding knob / Rotary knob

461AK SILENDO®

Aluminium noise-reducing interior door louvre, Dnew 32dB

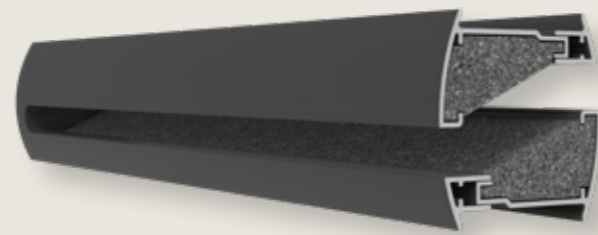

Material properties	Standard version
Material	Aluminium, alloy EN AW-6063 T66, noise-reducing UPVC foam
Surface treatment	Anodised (20 microns), chemically etched F1-E6 natural colour
End caps	UPVC, available in grey, black, or white
Mounting	Click system
Dimensions	
Flange	5 mm
Length x Height	425 mm x 48 mm
Door thickness	Min. 37 mm up to max. 43 mm

Performance	
Airflow rate	
Physical free area	27%
Visual free area	27%
Noise reduction dB	
Dn,e,w (C;Ctr)	32 (0;-2)

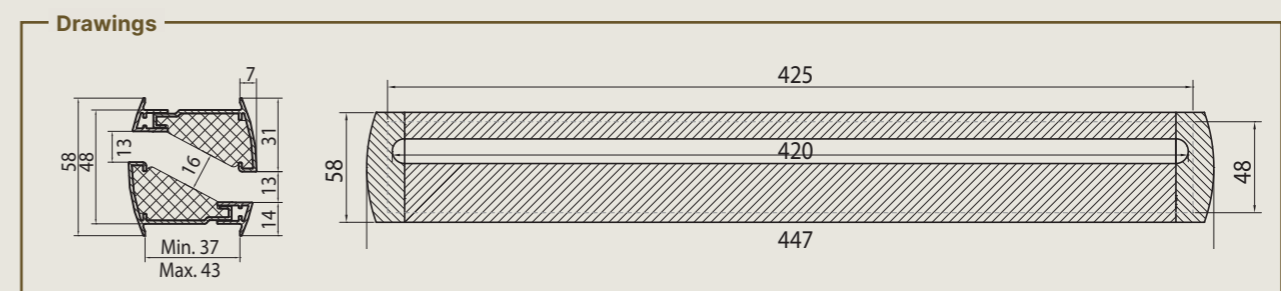

Stock models						
Dimensions (W x H) mm	Natural colour anodised	Renson Standard WHITE	RAL8019	flow rate at 2 Pa (m³/h)	flow rate at 10 Pa (m³/h)	flow rate at 20 Pa (m³/h)
425 x 48	10481	10482	13919	25.1	56.1	79.4

Available options	
• Finish:	Powder coating: non-standard powders

INSIDE DOOR

464/2 INCENDO®

Aesthetic fire-resistant louvre for interior doors, non-see-through and fire resistant up to 60 minutes



Performance		
Airflow rate		
Physical free area	51%	
Visual free area	61%	
Air supply	Resistance factor K	10.3
	Flow coefficient C	0.312
	Airflow rating	2
Air extraction	Resistance factor K	10.3
	Flow coefficient C	0.312
	Airflow rating	2
IP rating		
IP2XD		
Fire rating		
(wooden) door panel (50 mm) (max. 600 × 400 mm)	EI60/EW60 (ve i↔0)	
(wooden) door panel (40 mm) (max. 600 × 400 mm)	EI30/EW30 (ve i↔0)	

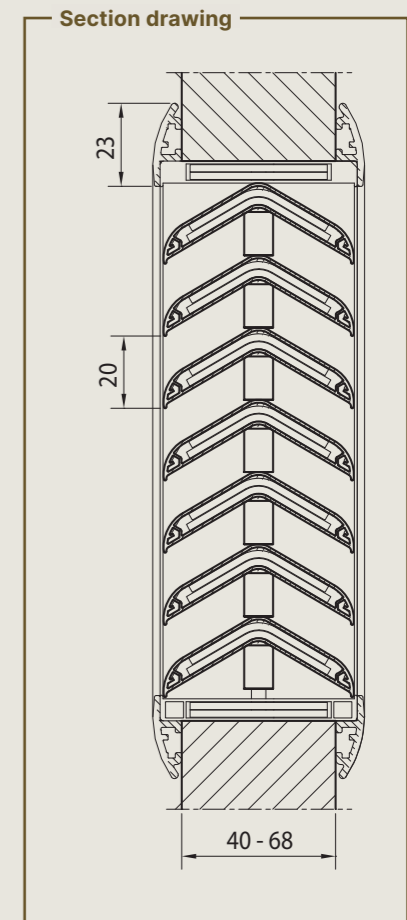

Operation: In case of fire, ventilation is cut off by the intumescence of the blades (starting at 100 °C). The louvre acts as a static fire damper for 60 minutes.
Not water resistant

Material properties	Standard version
Material	Polystyrene-Palusol
Available colours	RAL 9022 (light grey), RAL 9016 (white) and RAL 7024 (dark grey)
Dimensions	
Blade pitch	20 mm
Flange	16 mm
Preferred width	100 mm + (n x 50)
Preferred height	100 mm + (n x 50)
Minimum dimensions (W x H)	100 × 100 mm
Maximum width	800 mm
Maximum height	400 mm
Maximum louvre surface area	0.32 m ²

Stock models					
Dimensions (W x H) mm	RAL 9016 White	RAL 9022 Grey	flow rate at 2 Pa (m ³ /h)	flow rate at 10 Pa (m ³ /h)	flow rate at 20 Pa (m ³ /h)
400 × 200	9806	17475	107.44	240.20	339.80

INSIDE
DOOR

468AK/2

Aluminium noise-reducing interior door louvre, Rw 8dB



Performance		
Airflow rate		
Physical free area		29%
Visual free area		29%
Air supply	Resistance factor K	87.3
	Flow coefficient C	0.107
	Airflow rating	4
Air extraction	Resistance factor K	89
	Flow coefficient C	0.106
	Airflow rating	4
Noise reduction dB		
Rw (C;Ctr) dB(A)		8 (-1;-2)
f in Hz		R in dB
63		2.5
125		6.2
250		5.1
500		4.6
1000		5.1
2000		12.5
4000		18.5

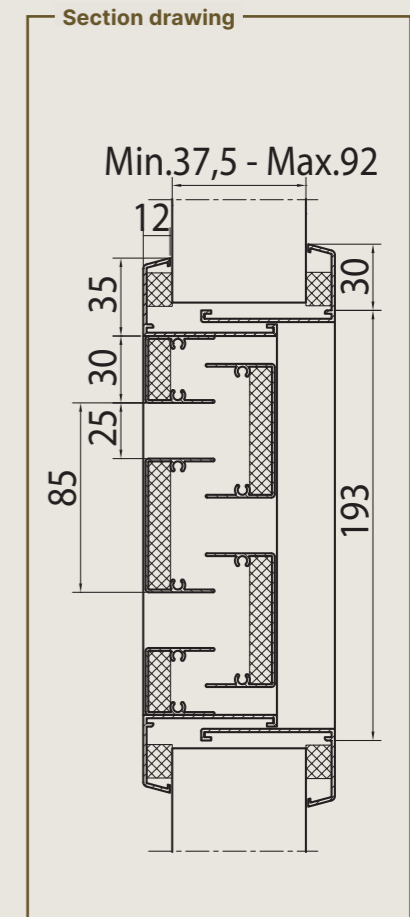

Material properties	Standard version
Material	Aluminium, alloy EN AW-6063 T66
Surface treatment	Anodised (20 microns), chemically etched F1-E6 natural colour
Mounting	Mounting screws included
Dimensions	
Blade pitch	85 mm
Flange	25 mm
For panel thicknesses between	38 - 92 mm
Minimum dimensions (W x H)	200 x 193 mm
Maximum width	800 mm
Maximum height	788 mm
Available height	180 + (n x 85)
Maximum louvre surface area	0.63 m ²

Stock models				
Dimensions (W x H) mm	Renson standard white	flow rate at 2 Pa (m ³ /h)	flow rate at 10 Pa (m ³ /h)	flow rate at 20 Pa (m ³ /h)
292 x 193	8321	25.00	55.90	79.10
382 x 278	10856	50.00	111.80	158.10
432 x 363	10857	75.00	167.7	237.20
452 x 448	8322	100.00	223.60	316.20

Available options

- **Finish:** Anodised: layer thickness 25 microns / other colours / other textures (E1-E10)

469 INVISIDO®

Unobtrusive aluminium interior door louvre, Dnew 28dB

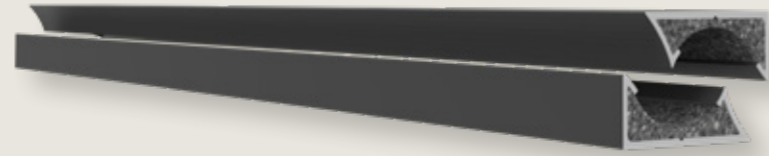

Material properties	Standard version
Material	Aluminium, alloy EN AW-6063 T66
UPVC end caps	Grey, black or white
Surface treatment	Anodised (20 microns), chemically etched F1-E6 natural colour
Mounting	Mounting screws included
Dimensions	
For panel thicknesses between	+/- 35 mm
Minimum length	500 mm
Maximum length	2000 mm

Performance	
Noise reduction dB	
D _{n,e,w} (C;C _{tr})	28 (-1;0)

Stock models							
Dimensions (W x H) mm	Natural colour anodised F1	Renson standard WHITE	RAL 9005	RAL 1015	flow rate at 2 Pa (m³/h)	flow rate at 10 Pa (m³/h)	flow rate at 20 Pa (m³/h)
725 x 24	16246	10858	8702	16247	22.23	49.74	70.30
825 x 24	8323	8324	8703	10859	25.30	56.60	80.00
925 x 24	16248	16249	10860	8704	28.37	63.46	89.7

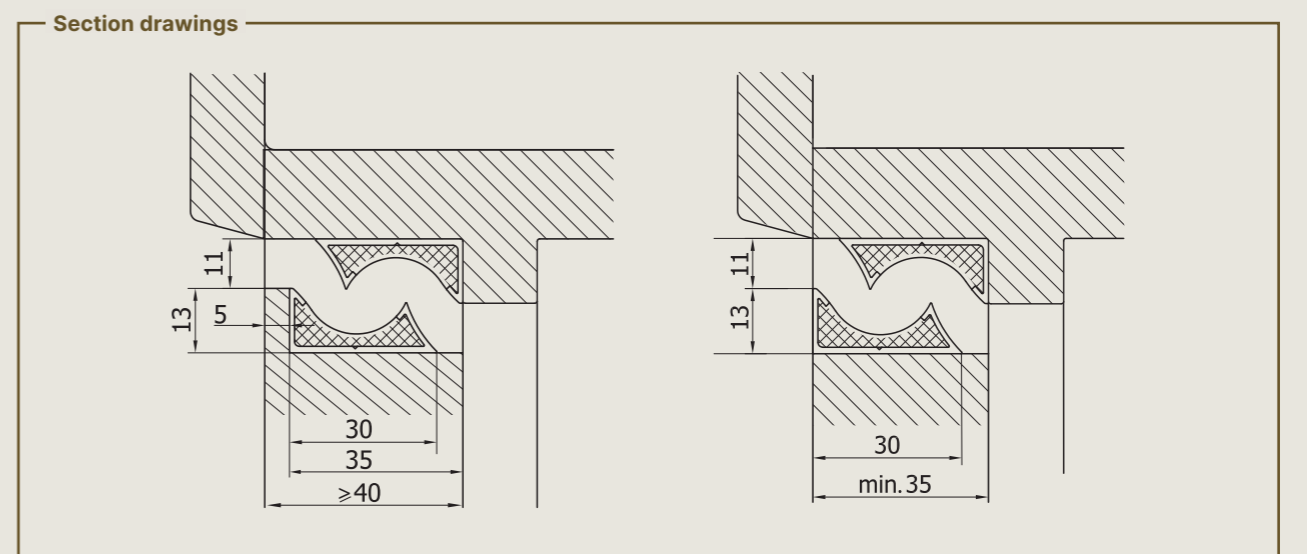

Available options	
• Finish:	Powder coating: non-standard powders

INSIDE DOOR

761

PVC interior door louvre



Dimensions (W x H) mm	White	Brown	Black	flow rate at 2 Pa (m³/h)	flow rate at 10 Pa (m³/h)	flow rate at 20 Pa (m³/h)
450 × 90	8358	8724	10882	39.9	89.2	126.2

Material properties	Standard version
Material	PVC
Dimensions	
Blade pitch	16 mm
Flange	15 mm
For panel thicknesses between	30 - 43 mm

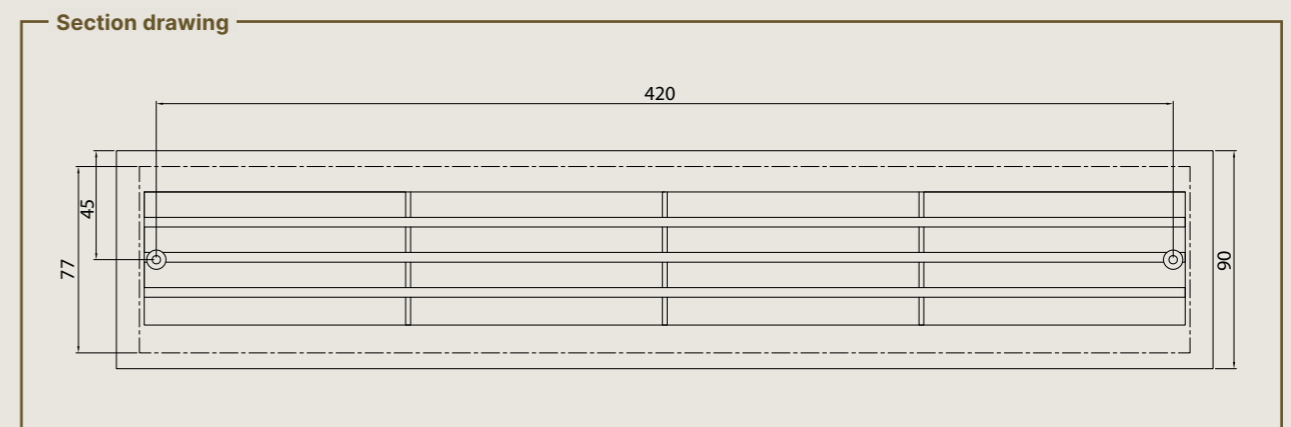

INSIDE DOOR

FLOOR / CONVECTOR GRILLES FOR INSIDE APPLICATIONS

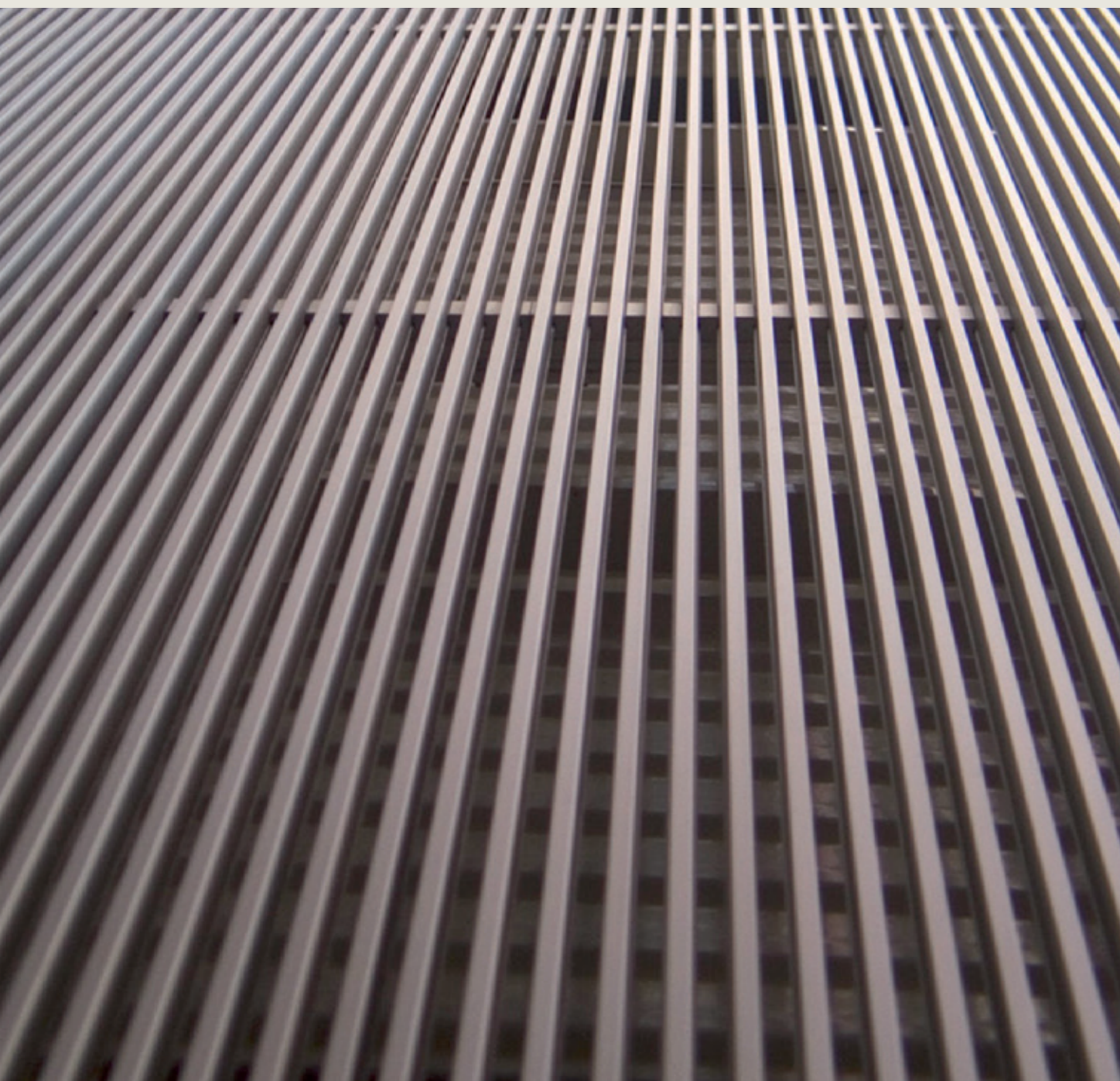

INSIDE
FLOOR/CONVECTOR

311

Aluminium floor louvre

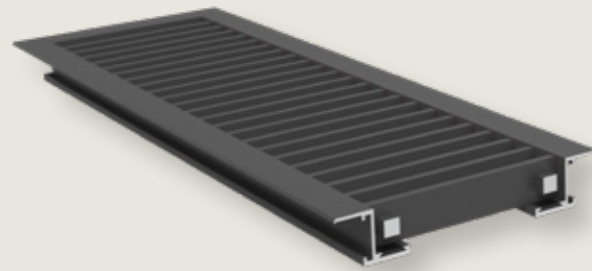

Blades across the width

Material properties	Standard version	
Material	Aluminium, alloy EN AW-6063 T66	
Noise reduction	Fitted with a noise-reducing rubber strip	
Surface treatment	Anodisation (20 microns), chemically etched F1-E6 natural colour	Polyester powder coating (60-80 micron) Seaside quality A & Standard powders
Bracket type	Floor brackets no. 231 included	
Dimensions	311/1 - 311/2	311/3
Blade pitch	16.5 mm	
Recess depth	Variable	
Flange	14 mm	
Minimum dimensions (L x W)	100 x 100 mm	85 x 85 mm
Maximum length	3500 mm (starting from 1300 mm, louvre comes in multiple parts)	1300 mm
Maximum width	1215 mm	1200 mm

If the louvre width is > 650 mm, a supporting structure is required.

Performance

Airflow rate

Physical free area	76%
Visual free area	76%

Section drawings

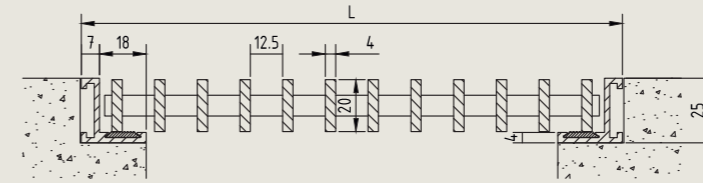

311/1: Floor louvre or covers with L frame without flange

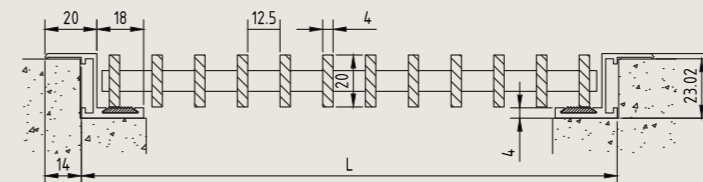

311/2: Floor louvre or covers with Z frame with flange

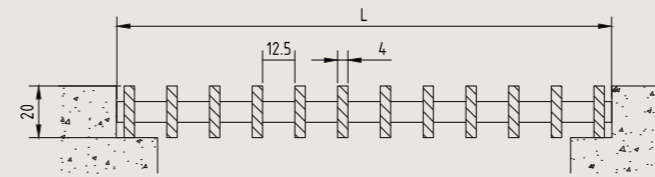

311/3: Floor louvre or covers without frame

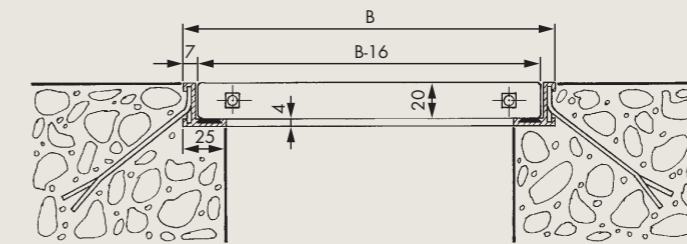

Available options

- **Frame type:** 1- L-frame / 2- Z-frame / 3- No frame
- **Finish:** Anodised: layer thickness 25 microns / other colours / other textures (E1-E10)
- **Special shapes**

392

Aluminium linear bar louvre

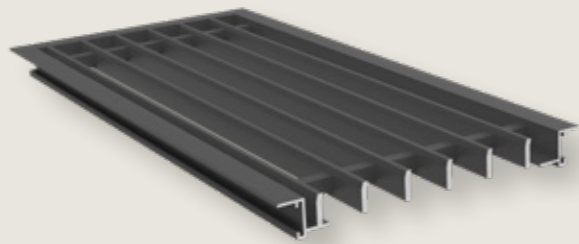

Performance		
Airflow rate		
Physical free area		76%
Visual free area		76%
Air supply	Resistance factor K	5.7
	Flow coefficient C	0.419
	Airflow rating	1
Air extraction	Resistance factor K	5.7
	Flow coefficient C	0.416
	Airflow rating	1

Section drawings

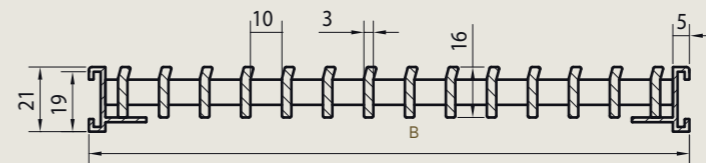

392/1 Linear bar louvre with L frame without flange

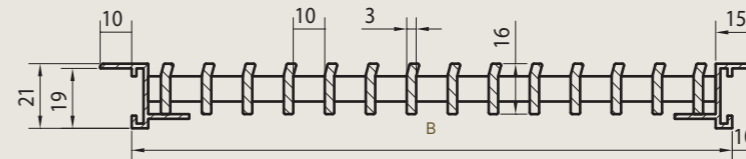

392/2: Linear bar louvre with Z frame with flange

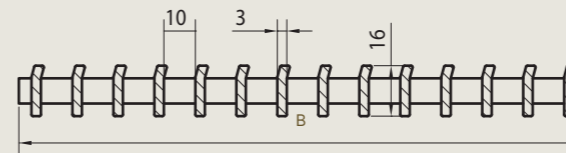

392/3: Linear bar louvre without frame

Blades across the width / Not suitable for foot traffic

Material properties	Standard version	
Material	Aluminium, alloy EN AW-6063 T66	
Surface treatment	Anodisation (20 microns), chemically etched F1-E6 natural colour	Polyester powder coating (60-80 micron) Seaside quality A & Standard powders
Dimensions	392/1 - 392/2	392/3
Blade pitch	13 mm	
Recess depth	Variable	
Flange	10 mm	
Minimum dimensions (L x W)	130 × 55 mm	120 × 45 mm
Maximum length	3500 mm (starting from 1600 mm, louvre comes in multiple parts)	1600 mm
Maximum width	311 mm	300 mm

Available options

- **Frame type:** 1- L-frame / 2- Z-frame / 3- No frame
- **Finish:** Anodised: layer thickness 25 microns / other colours / other textures (E1-E10)
Powder coating: pre-treatment in accordance with Seaside OX (pre-anodisation) / non-standard powders
- **Special shapes**

394

Aluminium linear bar louvre for self-assembly

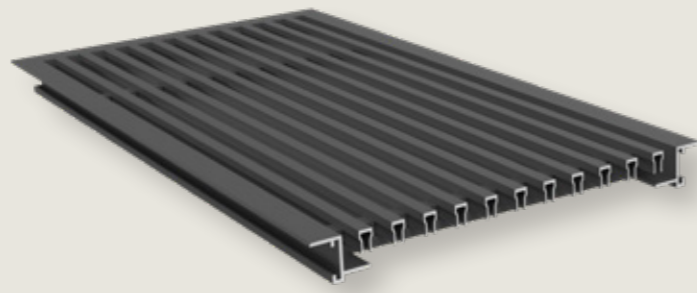

Performance

Airflow rate

Physical free area	59%
Visual free area	59%

Section drawings

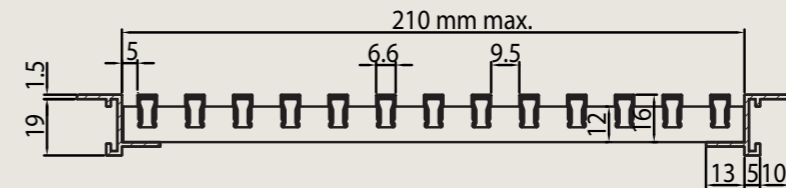

394/2: Linear bar louvre with frame with flange

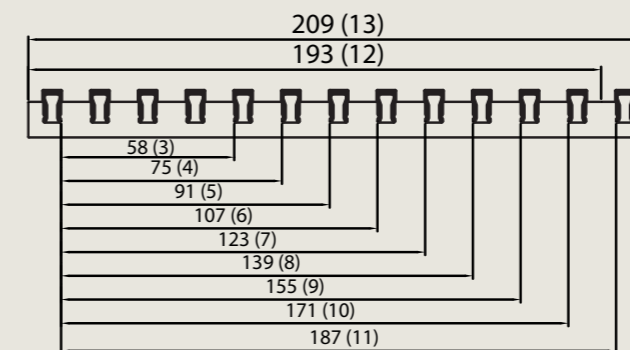

394/3: Linear bar louvre without frame

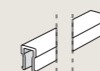

Ref. 394/08

Blades:
5600 mm (L)

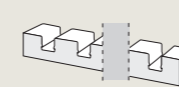

Ref. 394/06

Clips profile:
(crosspiece)
209 mm (L)



Ref. 394/02

Frame profile:
3000 or 6000 mm (L)



Ref. 394/04

Fixing corner for frame
installation

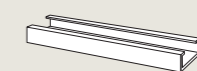

Ref. 394/10

U profile
To expand the clips profile (for
widths over 209 mm) 3000 mm
(L)

Blades across the length / Not suitable for foot traffic

Material properties	Standard version	
Material	Aluminium, alloy EN AW-6063 T66	
Surface treatment	Anodisation (20 microns), chemically etched F1-E6 natural colour	Polyester powder coating (60-80 micron) Seaside quality A & Standard powders
Dimensions	394/2	394/3
Blade pitch	16.5 mm	
Recess depth	Variable	
Flange	10 mm	
Minimum dimensions (L x W)	110 × 55 mm	100 × 45 mm
Maximum length	3510 mm	3500 mm
Maximum width	220 mm (joined: 1055 mm)	209 mm (joined: 1045 mm)

Number of crosspieces/length

- 300 - 500 mm: 2 pieces
- 501 - 900 mm: 3 pieces
- 901 - 1300 mm: 4 pieces
- 1301 - 1700 mm: 5 pieces
- 1701 - 2100 mm: 6 pieces
- 2101 - 2600 mm: 7 pieces
- 2601 - 3000 mm: 8 pieces

Available options

- **Type of frame:** 2- Z-frame / 3-No frame
- **Finish:** Anodised: layer thickness 25 microns / other colours / other textures (E1-E10)
Powder coating: pre-treatment in accordance with Seaside OX (pre-anodisation) / non-standard powders

OPTIONS

Many of our louvres can be equipped with one or more of the options below. You can find out which options are applicable to which louvre on the product pages in this brochure.

FINISH (COLOURS, PRE-TREATMENTS, COATING THICKNESS)

Aluminium naturally generates a protective oxide coating that protects against deterioration. This natural oxide layer is rough, uneven and very susceptible to dirt. As such, it is highly recommended and often necessary to preserve the aluminium with a surface treatment. Two different methods are available to do so: anodising or powder coating.

Anodising

A coating thickness of 20 microns is applied as standard. For applications in an aggressive atmosphere, a coating thickness of 25 microns is recommended. Anodisation is usually done using a natural shade of grey (F1), but can also be done in a limited number of other colours. Several parameters have an impact on the final colour in the anodisation process. As such, colour differences between profiles or other components cannot be ruled out. This applies to all anodisation colours, including the natural shade of grey. Despite these colour differences, anodisation is greatly favoured by many because of its natural character. If possible differences in colour must be avoided, powder coating is the preferred option, as this offers more control over the end colour.

Powder coating

A very wide colour palette and minimum risk of colour differences are the two main reasons why customers opt for powder coating. Powder coating is always done in a coating thickness of 60-80 microns. The pre-treatment that forms part of the powder coating process and ensures good adhesion of the paint to the aluminium can be carried out in different ways, depending on the environment to which the louvres will be exposed.

- **Standard pre-treatment**
Renson's louvres are powder coated as standard with a pre-treatment in accordance with Seaside Quality A. As such, all our louvres are properly protected, even in moderately aggressive environments such as coastal or industrial zones.
- **Pre-treatment in accordance with Seaside Quality OX (pre-anodisation).**
This pre-treatment offers even greater protection and is recommended when our products are used in highly aggressive environments such as near coastlines or in heavy industry zones.

Standard colours

Some louvre types are available from stock in standard dimensions and colours. The models available for the relevant products are listed in this brochure. For custom-made louvres, Renson offers an extensive range of more than 300 standard colours. Non-standard colours are also possible.

Gloss level

Most powder colours are available in matte or glossy versions, with glossy powders having a gloss level of

70% - 90% and matte powders having a gloss level of around 30%.

MOUNTING METHOD

Wall brackets

Most built-in louvres are supplied as standard with wall brackets that allow them to be installed invisibly in the wall. Depending on the type, different wall brackets come supplied.

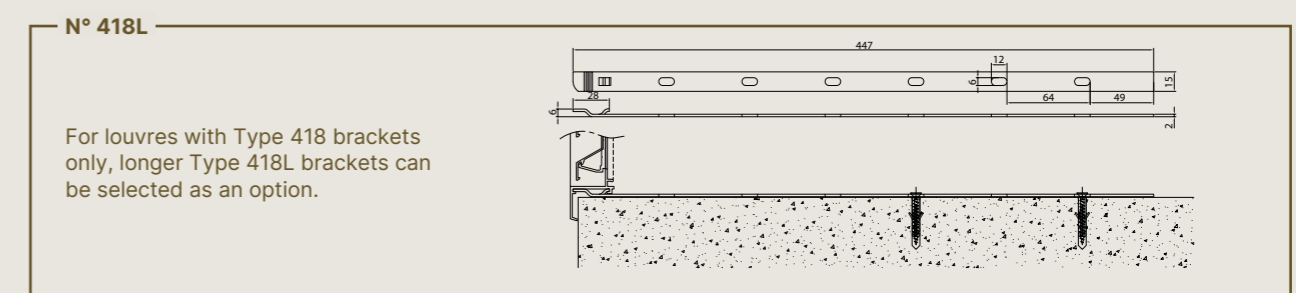
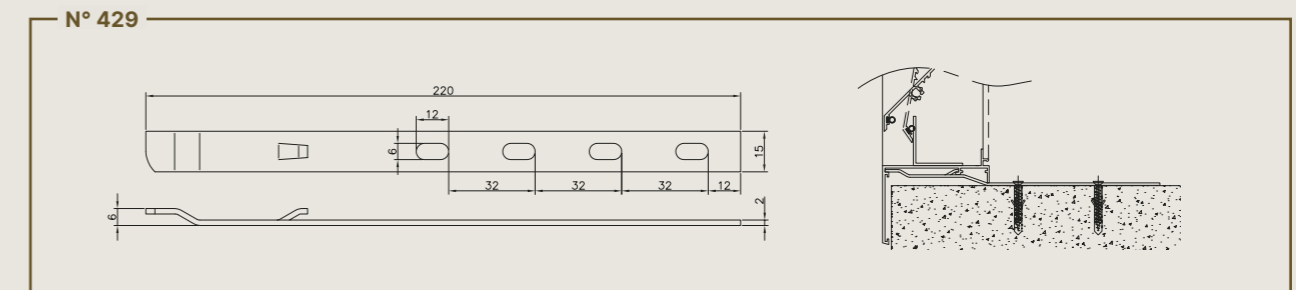
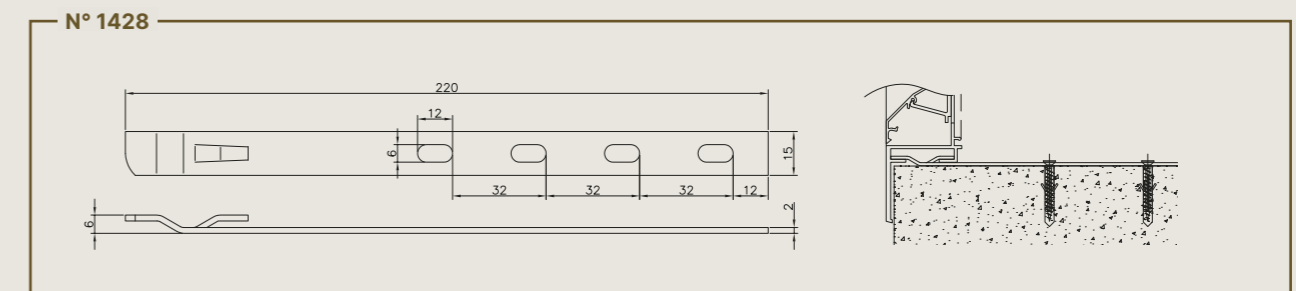
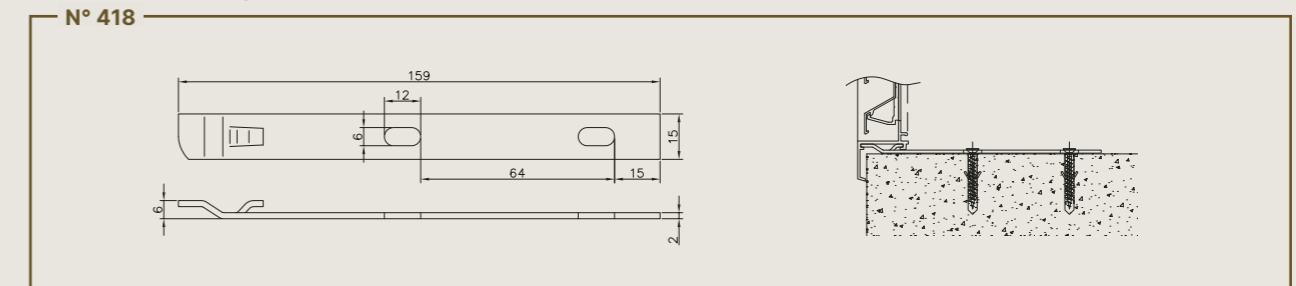

Spring clips

For some built-in louvres, Type 419 spring clips are also available as an alternative, allowing the louvre to be easily clamped into the opening.

Screw holes

If installation from the inside is not possible, screw holes can also be provided in the louvre flanges if required, so that the louvre can simply be screwed to the wall instead of using wall brackets.

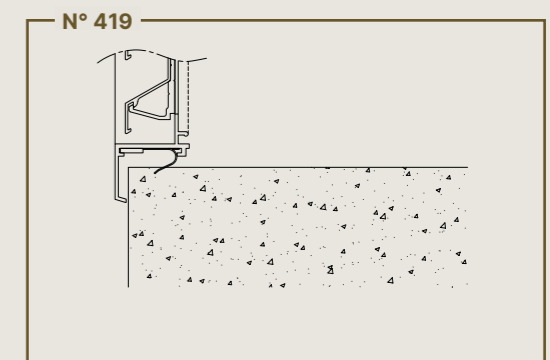

SPECIAL SHAPES

As louvres are part of the façade, they play a role in shaping the aesthetics of a building. To ensure they fit in as well as possible with the architecture of the building, we produce louvres in a huge variety of shapes as well as in all possible colours.



JOINING

If the louvre dimensions for your project are larger than the maximum dimensions, many louvre types can be supplied in sections that can be joined on site. The options and limitations are assessed on a project basis. Depending on the dimensions, it will be necessary in many cases to fit a sufficiently strong structural element behind the joints.

As an alternative to joining louvres together, a continuous louvre system with the same properties is also available for some louvre types. Continuous louvre systems offer the advantage of allowing you to cover large areas without being interrupted by intermediate frame profiles. Continuous louvre systems are delivered in individual parts for assembly at the construction site. More information is available on our website or in the 'Continuous louvre systems' brochure.

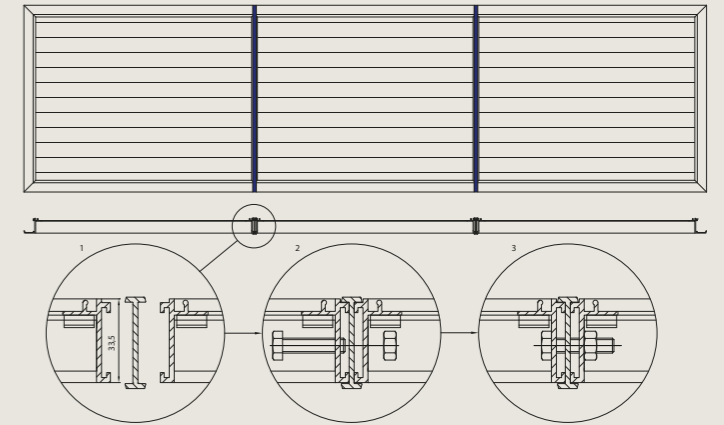

MESH

Many louvres come fitted with mesh as standard. The standard mesh type is shown on the product pages of these louvres. In most cases, it is also possible to choose a different type with a different mesh size or material quality, or a louvre without mesh.

Available types:

Mesh size:

- 2.3 mm x 2.3 mm: insect mesh – frequent cleaning recommended to prevent the openings from clogging up – when choosing the water channel option, always apply this type of mesh for optimal results.
- 6 mm x 6 mm: vermin mesh, recommended in applications where insect protection is not required but adequate protection against mice or other vermin is desirable.
- 10 mm x 10 mm or 20 mm x 20 mm: coarse mesh of this type is recommended in areas with high risk of contamination and clogging, and where protection against larger elements such as leaves or larger vermin is sufficient.

Quality:

- As standard, our louvres are fitted with mesh in AISI 304 stainless steel.
- For applications in high-stress environments such as coastal areas, grade AISI 316 is also an option. When Seaside Quality OX (pre-anodisation) or anodisation with layer thickness 25µ is selected for the aluminium, AISI 316 mesh is always used.

REMOVABLE MESH

In standard louvre designs, the mesh comes fitted as a fixed part of the louvre. Where frequent and thorough cleaning of the mesh is required, a removable mesh frame is available as an option. Frames of this type simply clip onto the back of the louvre, meaning they can easily be removed for cleaning.

The removable mesh frame comes with a water channel built in, offering improved rain resistance when 2.3 mm x 2.3 mm mesh is used.

Removable mesh can be selected as an option for a wide range of built-in and glazed-in louvre types (not for surface-mounted louvres). Additional restrictions on shape and dimensions also apply. More information about the possibilities is available on our RIO ordering platform or upon request. Adding removable mesh increases the total louvre depth by 18 mm.

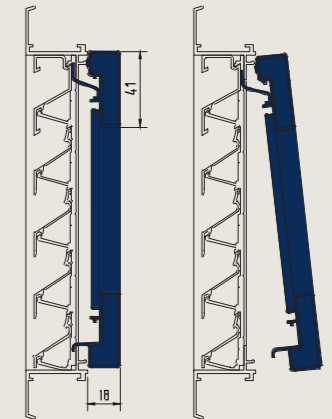

DUST FILTER

A Class G4 filter can be fitted to the back of the louvre. This type of filter is commonly used in ventilation systems and filters dust particles measuring $\pm 5 \mu\text{m}$ (0.005 mm) and above. G4 filters filter more than 90% of these dust particles from the air, making them the best category of their kind.

Adding a dust filter increases the total louvre depth by 21 mm. The presence of a filter also has a major impact on airflow. (The K factor should be increased by 25.93 in new condition and by 185.19 in highly polluted condition.)

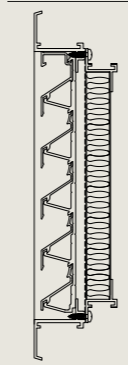

WATER CHANNEL

A water channel in a louvre offers better drainage of rainwater collected by the mesh and improves the overall rain resistance of the louvre as a result. As such, this option only makes sense in combination with fine 2.3 mm x 2.3 mm mesh. Adding a water channel increases the total louvre depth by 17 mm.

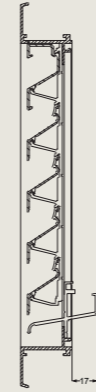

DRIP PROFILE

Just like a sill under a window, the purpose of a drip profile at the bottom of a louvre is to move any water drained from the louvre away from the wall in order to avoid excessive marking by water running down the wall. As such, this option is typically provided in built-in louvres.



COUNTERFRAME

A counterframe is used when a neat finish is required at both the front and back of a louvre. In door louvres, a counterframe is a basic part of the product. In built-in louvres, it is available as an option. Two types of counterframe are available for different panel/wall thicknesses. Details of the thicknesses available are shown on the product pages.

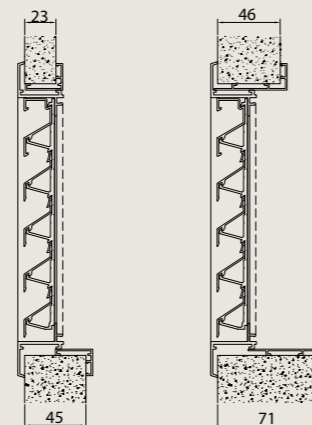

ALTERNATIVE FLANGE WIDTH (OUTSIDE/BUILT-IN LOUVRES)

Built-in louvres are available with a flange as standard, and in many cases, without a flange as an option. If required, louvres can also be supplied with narrower flanges or with different flange widths on each side.

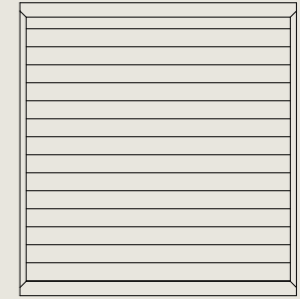

ALTERNATIVE GLASS SIZES (GLAZED-IN LOUVRES)

When louvres are used in the same glass size as the type of glazing used, the same glazing bars can be used everywhere. As such, most of our glazed-in louvres are available for different glass thicknesses. Typical thicknesses are 24mm, 28mm or 32mm. Other thicknesses are also available upon request.

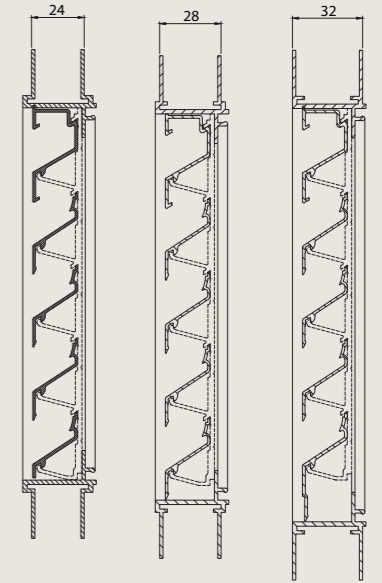

CLOSABLE

With sliding vents

Some louvre types can be fitted with sliding vents on the inside, which can be used to close them off or adjust the flow rate. Depending on the dimensions, the sliders are fitted vertically or horizontally.

The sliders can be controlled using a simple slider or rotary knob, a cord or rod, or using a linear actuator. Louvres with sliders are always fitted with 2.3 mm x 2.3 mm stainless steel mesh.

The use of sliding vents limits the airflow of the louvre.

It also limits the possible dimensions. See our RIO ordering platform or contact us for more info.

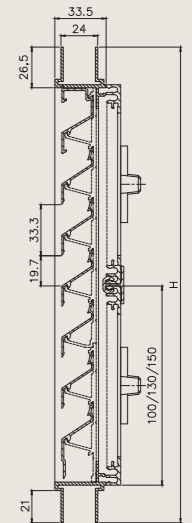

With hatch

A limited number of louvres measuring between 200mm and 400mm in both width and height can also be made closable by means of a thermally insulated hatch (U = 3 W/m²K).

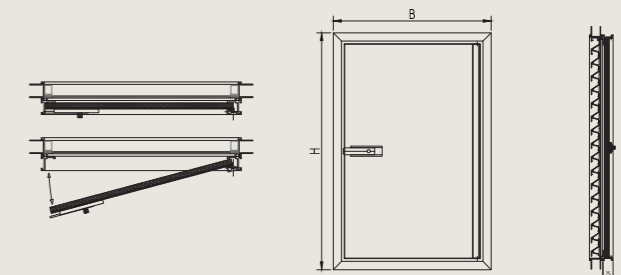

Type 427 and 427GL louvres: controls

Our closable Type 427 and 427GL louvres can be controlled in different ways:

Control type – min. height	427	427GL
/1 Standard version with controls directly on the louvre	290 mm	377 mm
/2 Louvre with cable control	390 mm	477 mm
/3 Louvre with Ultraflex control Control possible up to a distance of 7000 mm from the louvre	590 mm	677 mm
/4 Louvre with linear actuator control	390 mm	477 mm
/5 Louvre with air pressure control	390 mm	477 mm
/6 Louvre with fire damper actuator	390 mm	477 mm

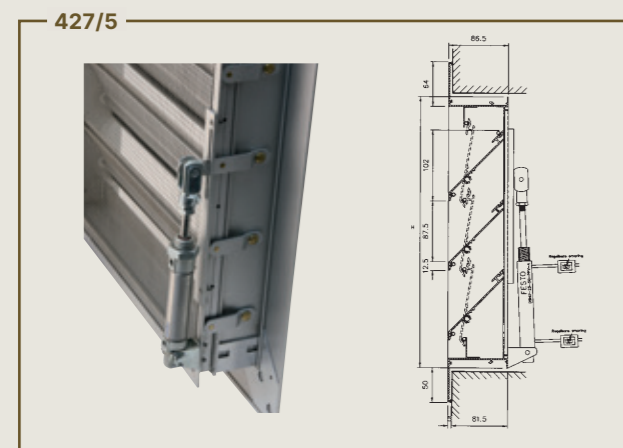
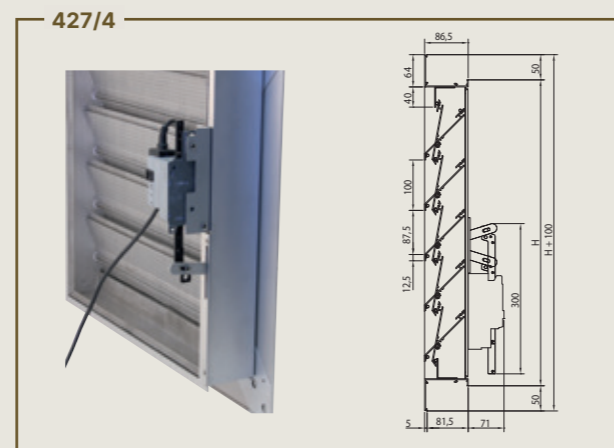
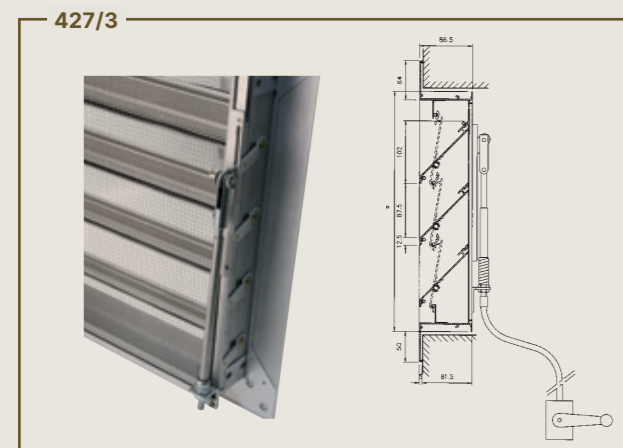
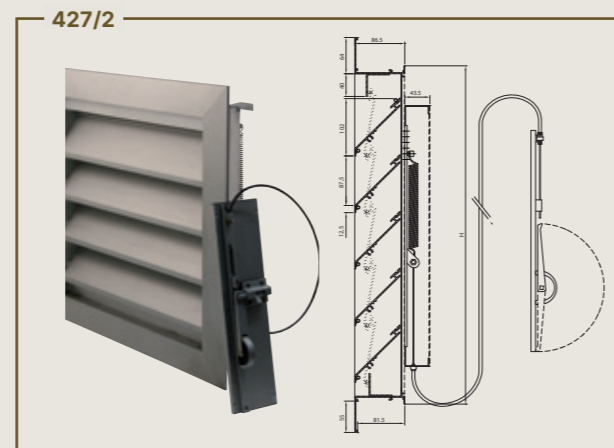
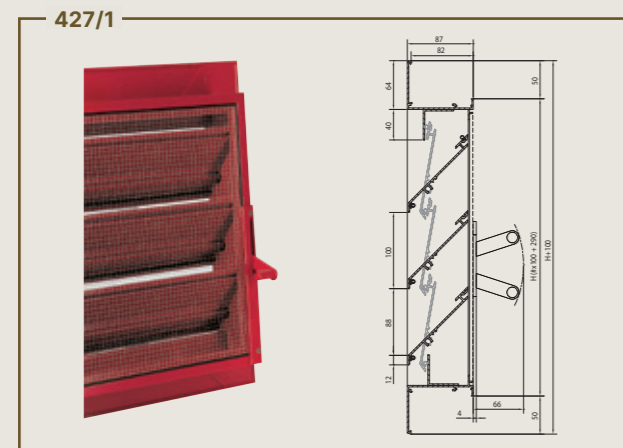

PANEL, PLENUM OR CONNECTION SOCKET ON REAR SIDE

Some louvres are used as an aesthetic element in a façade. Alternatively, sometimes only part of the louvre surface is needed for airflow. In these cases, our louvres can be fully or partially closed off at the rear using a plate or panel, thermally insulated or otherwise.

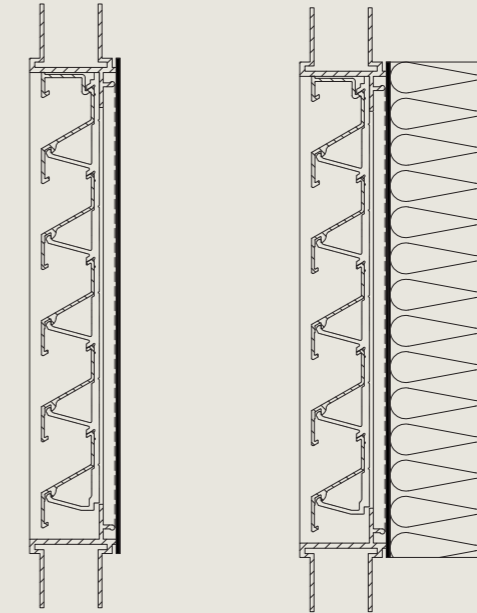

In Type 414THF louvres – a special version of Type 414 – the insulated panel extends into the window rebate to achieve an optimal thermal break in the building shell. Depending on the panel thickness selected, different U values can be obtained.

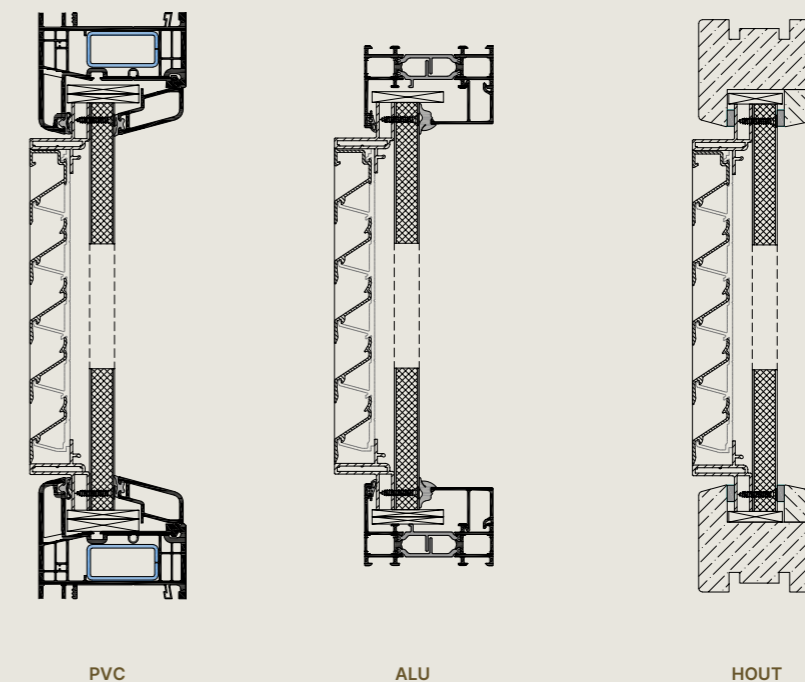





All images shown are for illustration purposes only and represent a snapshot of a practical situation. The actual product may vary due to modifications to the product. Renson reserves the right to make technical changes to the products shown. The latest brochures can be downloaded from renson.net